

INFORMATION TO USERS

This manuscript has been reproduced from the microfilm master. UMI films the text directly from the original or copy submitted. Thus, some thesis and dissertation copies are in typewriter face, while others may be from any type of computer printer.

The quality of this reproduction is dependent upon the quality of the copy submitted. Broken or indistinct print, colored or poor quality illustrations and photographs, print bleedthrough, substandard margins, and improper alignment can adversely affect reproduction.

In the unlikely event that the author did not send UMI a complete manuscript and there are missing pages, these will be noted. Also, if unauthorized copyright material had to be removed, a note will indicate the deletion.

Oversize materials (e.g., maps, drawings, charts) are reproduced by sectioning the original, beginning at the upper left-hand corner and continuing from left to right in equal sections with small overlaps. Each original is also photographed in one exposure and is included in reduced form at the back of the book.

Photographs included in the original manuscript have been reproduced xerographically in this copy. Higher quality 6" x 9" black and white photographic prints are available for any photographs or illustrations appearing in this copy for an additional charge. Contact UMI directly to order.

UMI

University Microfilms International
300 North Zeeb Road
Ann Arbor, Michigan 48106
Telephone: (616) 763-0700
Telex: 9800
Fax: (616) 763-4600

Order Number 1351662

Solubility of zinc in the Merrill-Crowe process

Fang, Ming, M.S.

University of Nevada, Reno, 1992

U·M·I

300 N. Zeeb Rd
Ann Arbor, MI 48106

University of Nevada-Reno

SOLUBILITY OF ZINC IN THE MERRILL-CROWE PROCESS

**A thesis in partial fulfillment of the requirements for the
degree of Master of Science in Metallurgy**

by

Ming Fang

Maurice C. Fuerstenau, Thesis Advisor

November 1992

The thesis of Ming Fang is approved:

Maurice J. Surtman
Thesis Advisor

S. J. ...
Department Chair

...
Dean, Graduate School

University of Nevada
Reno

November 1992

ACKNOWLEDGEMENTS

I wish to express my sincere thanks to Dr. M. C. Fuerstenau for the guidance and support throughout my graduate career and especially in this research project. I extend my appreciation to the Center for Precious Metals, University of Nevada-Reno, for providing the financial support necessary to complete this investigation.

Sincere gratitude and thanks also go to Dr. M. Misra and Dr. J. H. Nelson for their suggestions and advice. My special thanks go to Ms. G. Chi for her help and suggestions and to Mr. P. Leckler and Mr. M. Desilets for their assistance and use of the Atomic Absorption Spectrometer. I am also grateful to Mr. M. C. Jensen for his help with the electron microscopy carried out in this study.

ABSTRACT

The solubility of metallic zinc occurring in the cementation of gold and silver has been established in a laboratory-size Merrill-Crowe apparatus. The effect of several parameters, namely, cyanide, oxygen, gold, silver, and lead nitrate concentrations on the solubility of zinc were determined.

In this system, an increase in concentration of cyanide, oxygen and gold or silver increases zinc solubility but does not always promote the efficiency of gold and silver precipitation. Zinc is consumed largely by oxygen and water. A single mechanism of the enhancement of precious metal cementation in the presence of lead nitrate does not appear to be operative. The enhancement is probably due to several phenomena.

LIST OF TABLES

Table 2.1: Stability constants of selected Au(I) and Au(III) complexes.

Table 2.2: Stability constants of selected Ag(I) complexes.

Table 2.3: Stability constants of selected zinc complexes.

Table 2.4: Thermodynamic data for Au-Zn-CN-H₂O and Au-H₂O systems at 25°C.

Table 2.5: Thermodynamic data for Ag-Zn-CN-H₂O and Ag-H₂O systems at 25°C.

Table 3.1: Material employed.

Table 4.1: Experimental reproducibility.

LIST OF FIGURES

- Figure 1.1: Flowsheet for gold and silver recovery by the Merrill-Crowe Process.
- Figure 2.1: Dissolution of zinc in cyanide solution.
- Figure 2.2: Eh-pH diagram for the Au-Zn-H₂O system at 25°C; [Au] = 4×10^{-7} mol/L
- Figure 2.3: Eh-pH diagram for the Ag-Zn-H₂O system at 25°C; [Ag] = 2.5×10^{-4} mol/L
- Figure 2.4: Eh-pH diagram for the Au-Zn-CN-H₂O system at 25°C with different cyanide concentrations; [Au] = 4×10^{-7} mol/L; (a) [CN] = 10^{-2} mol/L; (b) [CN] = 2×10^{-3} mol/L.
- Figure 2.5: Eh-pH diagram for the Ag-Zn-CN-H₂O system at 25°C with different cyanide concentrations; [Ag] = 2.5×10^{-4} mol/L; (a) [CN] = 10^{-2} mol/L; (b) [CN] = 2×10^{-3} mol/L.
- Figure 2.6: Eh-pH diagram for the Au-Zn-CN-H₂O system at 25°C with different dissolved gold concentrations; [CN] = 10^{-2} mol/L; (a) [Au] = 4×10^{-7} mol/L; (b) [Au] = 10^{-5} mol/L.
- Figure 2.7: Eh-pH diagram for the Ag-Zn-CN-H₂O system at 25°C with different dissolved silver concentrations; [CN] = 10^{-2} mol/L; (a) [Ag] = 2.5×10^{-4} mol/L; (b) [Ag] = 3×10^{-5} mol/L.
- Figure 3.1: Schematic diagram of an experimental apparatus for room temperature.

- Figure 4.1: Effect of cyanide concentration on zinc solubility in gold cyanide systems; [Au] = 2 ppm, pH 10.7, 22°C.
- Figure 4.2: Solubilities of zinc in low cyanide concentration solution; [NaCN] = 1.5×10^{-4} M, pH 10.7, 22°C.
- Figure 4.3: Effect of cyanide concentration on zinc solubility in silver cyanide systems; [Ag] = 5 ppm, pH 10.7, 22°C.
- Figure 4.4: Effect of initial dissolved oxygen concentration on zinc solubility; [NaCN] = 0.5 g/L, pH 10.7, 22°C.
- Figure 4.5: Effect of initial dissolved oxygen concentration on zinc solubility; [NaCN] = 0.5 g/L, pH 10.7, 22°C.
- Figure 4.6: Effect of initial dissolved oxygen concentration on zinc solubility; [Au] = 2 ppm, pH 10.7, 22°C.
- Figure 4.7: Effect of initial dissolved oxygen concentration on zinc solubility, [Ag] = 5 ppm, pH 10.7, 22°C.
- Figure 4.8: Effect of gold ion concentration on zinc solubility; pH 10.7, 22°C, (a) [NaCN] = 0.1 g/L, (b) NaCN = 0.5 g/L.
- Figure 4.9: Effect of silver ion concentration on zinc solubility; pH 10.7, 22°C, (a) [NaCN] = 0.1 g/L, (b) [NaCN] = 0.5 g/L.
- Figure 4.10: The effect of gold concentration on the rate of cementation.
- Figure 4.11: Effect of initial dissolved oxygen concentration on zinc solubility; pH 10.9, 22°C.
- Figure 4.12: Solubility of zinc as a function of gold concentration. (a) NaCN 0.1 g/L, (b) NaCN 0.5 g/L.

Figure 4.13: Solubility of zinc as a function of silver concentration.

(a) NaCN 0.1 g/L, (b) NaCN 0.5 g/L.

Figure 4.14: Schematic of gold precipitation on a zinc surface with lead salt addition.

Figure 4.15: Schematic of gold precipitation on a zinc surface without lead salt addition.

Figure 4.16: Current-potential scans for gold reduction from a solution of 0.05M KCN, 4mM KOH showing the effect of lead addition from 0 to 10 ppm.

Figure 4.17: Plots of the calculated ratio A_c / A_a in the $\text{Au}(\text{CN})_2^- / \text{Zn}$ metal displacement reaction showing the effect of lead addition.

Figure 4.18: Zinc anodic polarization curves.

Figure 4.19: SEM photograph of gold deposit on the zinc surface; $[\text{NaCN}] = 0.1\text{g/L}$, $[\text{Au}] = 40\text{ ppm}$, pH 10.7, 22°C, (a) no lead, (b) 10 ppm lead nitrate.

Figure 4.20: SEM photograph of silver deposit on the zinc surface; $[\text{NaCN}] = 0.5\text{g/L}$, $[\text{Ag}] = 40\text{ ppm}$, pH 10.7, 22°C, (a) no lead, (b) 10 ppm lead nitrate.

Figure 4.21: Effect of lead addition on zinc solubility in gold cyanide systems with different cyanide concentrations; $[\text{Au}] = 2\text{ppm}$, pH 10.7, 22°C, (a) $[\text{NaCN}] = 0.1\text{g/L}$, (b) $[\text{NaCN}] = 0.5\text{g/L}$.

Figure 4.22: Effect of lead addition on zinc solubility in gold cyanide systems

with different metal ion concentrations; $[\text{NaCN}] = 0.1 \text{ g/L}$, pH 10.7, 22°C , (a) $[\text{Au}] = 0.1 \text{ ppm}$, (b) $[\text{Au}] = 2 \text{ ppm}$.

Figure 4.23: Effect of lead addition on zinc solubility in silver cyanide systems with different cyanide concentrations; $[\text{Ag}] = 5 \text{ ppm}$, pH 10.7, 22°C , (a) $[\text{NaCN}] = 0.1 \text{ g/L}$, (b) $[\text{NaCN}] = 0.5 \text{ g/L}$.

Figure 4.24: Effect of lead addition on zinc solubility in silver cyanide systems with different metal ion concentrations; $[\text{NaCN}] = 0.5 \text{ g/L}$, pH 10.7, 22°C , (a) $[\text{Ag}] = 5 \text{ ppm}$, (b) $[\text{Ag}] = 40 \text{ ppm}$.

Figure 4.25: Effect of lead addition on zinc solubility: $[\text{NaCN}] = 1.5 \times 10^{-4} \text{ M}$, pH 10.7, 22°C .

TABLE OF CONTENTS

	Page
SIGNATURE PAGE -----	i
ACKNOWLEDGEMENT -----	ii
ABSTRACT -----	iii
LIST OF TABLES -----	iv
LIST OF FIGURES -----	v
TABLE OF CONTENTS -----	ix
CHAPTER	
1. INTRODUCTION -----	1
2. CHEMISTRY OF GOLD, SILVER, AND ZINC	
2.1. Gold, silver, and zinc and their compounds -----	7
2.2. Solubility of zinc in the Merrill-Crowe system -----	11
2.3. Thermodynamic considerations -----	13
2.4. Eh-pH Diagrams -----	15
3. EXPERIMENTAL APPARATUS AND PROCEDURES	
3.1. Materials -----	25
3.2. Apparatus -----	25
3.3. Experimental conditions -----	27
3.4. Experimental procedures -----	27
4. RESULTS AND DISCUSSION	
4.1. Cyanide concentration -----	32
4.2. Oxygen concentration -----	35

4.3. Gold and silver concentrations	38
4.4. Lead nitrate addition	47
5. CONCLUSIONS	64
6. REFERENCES	67
7. APPENDICES	72

1. INTRODUCTION

1.1 The Merrill-Crowe Process

The cyanide process as used for the extraction of gold and silver from their ores is generally considered to have been created by J. S. MacArthur and R. W. Forrest in 1887(1). After seven years, the use of zinc dust as a precipitant for gold and silver was patented by Sulman and Pichard(2). In the United States, this technology had not been used until Mr. C. W. Merrill applied it in 1897 at the Homestake Mine. The Crowe process for the removal of dissolved oxygen by vacuum from pregnant leach solutions was introduced in 1916(2). After that time, the Merrill method of utilizing zinc powder was soon combined with the Crowe process of oxygen removal, and the use of this combination was quickly adopted by the gold milling industry.

Figure 1.1 reveals a typical flowsheet for gold and silver recovery by the Merrill-Crowe process. As this system demonstrates, pregnant solution is clarified and passed through a deaeration tower where it is deoxygenated by vacuum. Following the deoxygenation process, zinc dust is added to the solution, reducing the precious metals in solution to their metallic state while simultaneously oxidizing zinc.

Relatively little attention has been focused on the relation between solubility of zinc and zinc effectiveness. Until 1960, most of the research regarding the Merrill-Crowe system was involved with plant procedures. More recent studies have been involved with the kinetics of gold and silver cementation on rotating discs or cylinders(3-9). In the late 1980's, Parga et al.(10,11) conducted comprehensive investigations on the mechanisms in

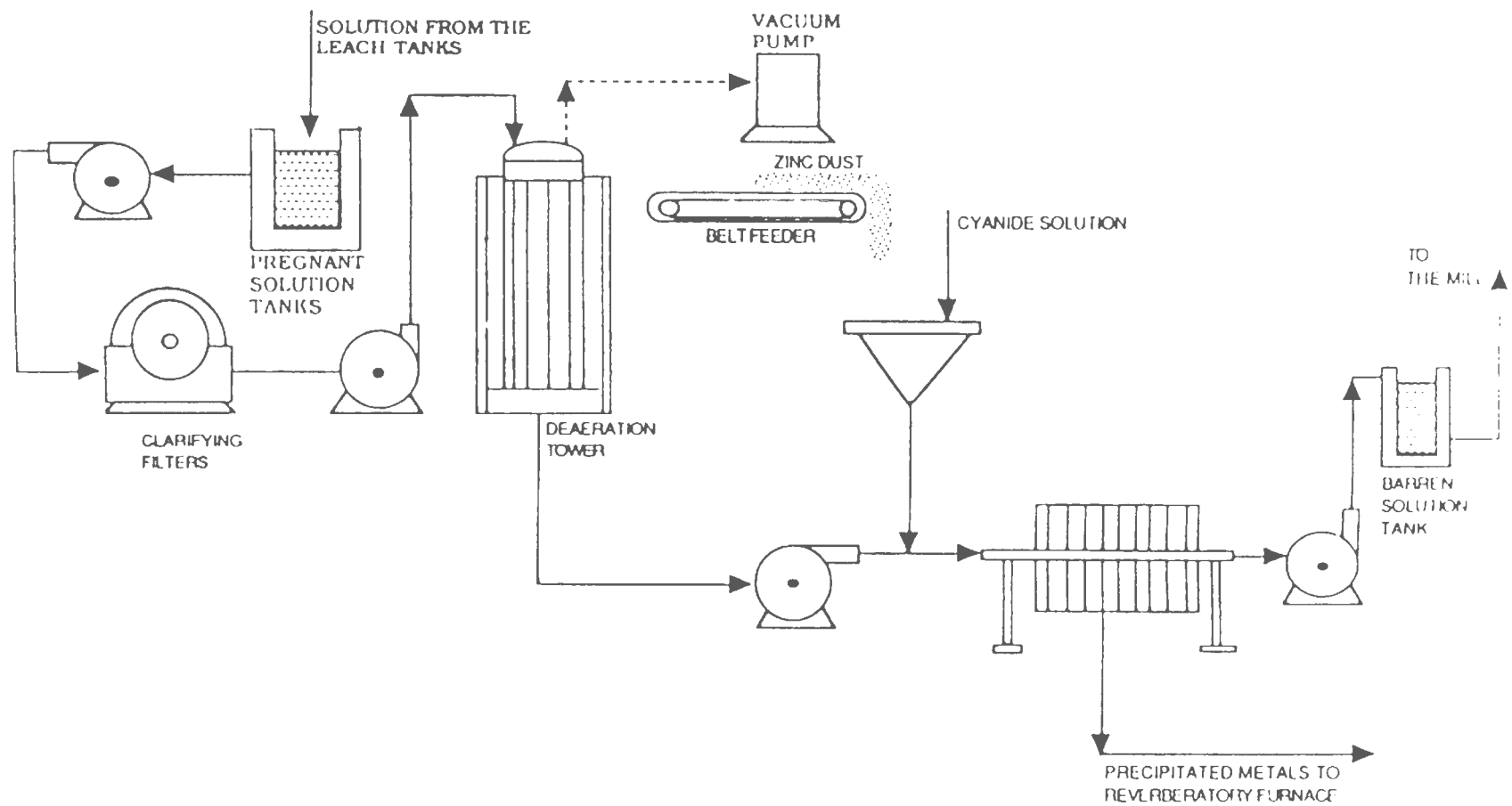

FIGURE 1.1. Flowsheet for gold and silver recovery by the Merrill-Crowe Process(11).

cementation reactions. They found that the zinc-dust cementation of precious metal from alkaline cyanide solution is controlled by mass transfer; the reaction is limited by boundary layer diffusion, and the reaction kinetics is first order. They also noted that the structure of the precious metal deposit is sensitive to small additions of other metal ions.

In practice, the efficiency of zinc utilization in Merrill-Crowe precipitation is commonly 20-25 percent and can be as low as 2 percent. The zinc which is not used in the replacement reaction with gold or silver, but is dissolved, is responsible for the inefficiency and contributes significantly to the cost of processing. In one operation in Nevada about 1275 pounds of zinc are added per day, and the efficiency of zinc utilization is about 20 percent. Annual cost of zinc powder is about \$375,000 for this operation. Approximately \$300,000 of this amount is not being utilized to recover dissolved gold and silver values.

A previous study was undertaken by Chi(12) to establish the solubility of zinc that occurs under various process conditions, i.e., concentration of cyanide, oxygen and lead nitrate, in the absence of dissolved gold and silver to better understand these losses of zinc. Since actual processing in Merrill-Crowe systems is effected in the presence of precious metal cyanide, knowledge of zinc solubility and mechanisms involved in the presence of dissolved gold and silver will be very useful, and this investigation was undertaken to establish this information.

1.2 Objective and Methodology

The objective of this investigation is to establish the solubility of metallic zinc in the presence of gold and silver cyanide as a function of cyanide, oxygen and lead nitrate concentrations.

A laboratory apparatus and procedure which allowed de-aeration of the solution to a desired level was used to simulate the vacuum deaeration of the Merrill-Crowe process.

2. CHEMISTRY OF GOLD, SILVER, AND ZINC

2.1 Gold, Silver and Zinc and their Compounds

1. Gold and its Compounds

Gold, atomic number 79, is a third row transition metal in Group IB of the Periodic Table. Gold is the most inert of the metallic elements. Oxygen, water and most acids cannot affect gold easily, so it is very resistant to corrosion and has great stability.

Although the characteristic electronic arrangement of group IB elements is $(n-1)d^{10}ns^1$ (13), there is no significant difference between the energies of the ns and $(n-1)d$ electrons. This explains the several oxidation states encountered with gold. Auric, Au(III), and aurous, Au(I), are the predominant oxidation states; other oxidation states, such as Au(II) and Au(V), are extremely rare and have no practical importance. Gold compounds are invariably bound covalently, and by far the majority form complexes; neither auric nor aurous ion is known to exist significantly. Au(I) exhibits linear two-fold coordination and Au (III) commonly exhibits four-fold coordination. Some compounds, such as Au_2O , AuO , Au_2O_3 , $Au(OH)_3$ etc., have been mentioned by some researchers (14) (15).

In aqueous solution, only complex anions of Au(I) and Au(III) are stable, and some of them are extremely stable. Table 2.1 lists some stability

Table 2.1. Stability constants of selected Au(I) and Au(III) complexes(16).

Ligard	Au(I), β_2	Au(III), β_4
CN ⁻	2×10^{38}	10^{56}
SCN ⁻	1.3×10^{17}	10^{42}
S ₂ O ₃ ²⁻	5×10^{28}	
Cl ⁻	10^9	10^{26}

Table 2.2. Stability constants of selected Ag(I) complexes (20).

Chemical Formula	Ag(I), β_i
AgCN ₂ ⁻	3×10^{20}
AgCN ₃ ²⁻	2.5×10^{21}
AgCN ₄ ³⁻	6.3×10^{20}
AgCN _s	4.57×10^{-15} (K_{sp})

Table 2.3. Stability constants of selected zinc complexes (20).

System	β_1	β_2	β_3	β_4
Zn-OH	1.41×10^4		1.18×10^{16}	7.76×10^{16}
Zn-CN ⁻	2×10^5	1.2×10^{11}	1.12×10^{16}	4.2×10^{19}

constants of Au(I) and Au(III) complexes. All of the researchers agree that the gold complex obtained after gold cyanidation is dicyanoaurate, $\text{Au}(\text{CN})_2^-$. The formation of $\text{Au}(\text{CN})_4^-$ is very rare. Finkelstein(16) has stated that under normal leaching conditions, the species, $\text{Au}(\text{CN})_2^-$, predominates by a factor of about 10^8 . The formation of $\text{Au}(\text{CN})_4^-$ is, therefore, neglected in the Merrill-Crowe system. This research concerns dicyanoaurate only.

2. Silver and its Compounds

Silver, atomic number 47, is a second row transition metal in Group IB of the Periodic Table. Like gold, silver has great chemical stability and corrosion resistance. Silver, also, is found in the native state in nature. In the IB group of elements, silver is the only one in which (+I) is the most characteristic oxidation state.

The most common silver oxide is Ag_2O . Other oxidation states, such as the (II) and (III) states, result in very powerful oxidants(17). $\text{Ag}(\text{II})$ is a transient species in aqueous solution, and $\text{Ag}(\text{III})$ exists only when stabilized through complex formation.

In aqueous solution silver salts are, at best, sparingly soluble except three simple silver salts, i.e., fluoride, nitrate and perchlorate (13). The $\text{Ag}(\text{I})$ ion forms many stable and soluble complexes, while the (II) and (III) states are powerful oxidizing agents, as mentioned previously, which react with water

itself (18). The predominant silver cyanide complex ion is $\text{Ag}(\text{CN})_2^-$; the higher complexes like $\text{Ag}(\text{CN})_3^{2-}$ and $\text{Ag}(\text{CN})_4^{3-}$ are stable only at high cyanide concentration (18). Silver cyanide, AgCN , precipitates when stoichiometric amounts of silver ion and cyanide ligand are mixed. $\text{Ag}(\text{I})$ ion forms soluble complexes, $\text{Ag}(\text{CN})_3^{2-}$ and $\text{Ag}(\text{CN})_4^{3-}$, readily in the presence of excess cyanide ion. Stability constants of some silver complexes are shown in Table 2.2.

3. Zinc and its Compounds

Zinc, atomic number 30, is a first row transition metal in Group IIB of the Periodic Table. In contrast to gold and silver, it exhibits high reduction characteristics. It is a relatively active metal and is not found free in nature. The compounds of zinc are found invariably in two oxidation states: $\text{Zn}(\text{II})$ and $\text{Zn}(\text{IV})$ with $\text{Zn}(\text{II})$ being by far the most important one.

Zinc forms only two oxides, ZnO and ZnO_2 , and one hydroxide, $\text{Zn}(\text{OH})_2$. Both ZnO and $\text{Zn}(\text{OH})_2$ are insoluble in water, but they are amphoteric. They can dissolve in acid solution to give zinc ions, Zn^{2+} , and in alkaline solutions where the bizincate or zincate ions, HZnO_2^- and ZnO_2^{2-} , are found according to the following equilibria(19):

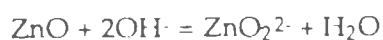
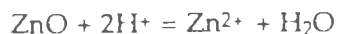

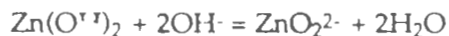
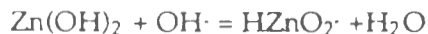
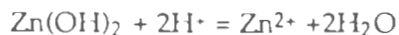

Zinc hydroxide precipitates in the pH range 7 to 13 in the absence of complexing ligands. When the hydroxyl concentration is very high, some zincates will be formed, such as $[\text{Zn(OH)}_3]^-$, $[\text{Zn(OH)}_4]^{2-}$ and $[\text{Zn(OH)}_3\text{H}_2\text{O}]^-$.

Zinc has a large tendency to form covalent compounds and coordination complexes (20). The divalent zinc cation forms many complexes in solution. The diffuse nature of the d orbitals makes the ion, Zn^{2+} , readily deformable and favors the formation of stable covalent complexes with polarizable ligands such as ammonia, amines and the cyanide ion. Table 2.3 shows a representative example of the stability constants of hydroxide and cyanide Zn(II) complexes.

2.2 Solubility of Zinc in the Merrill-Crowe System

In alkaline cyanide solutions containing gold or silver ion, the dissolution of zinc dust is mainly achieved by the following reactions:

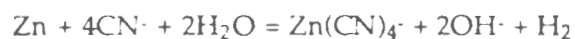
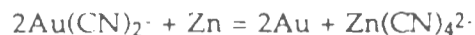

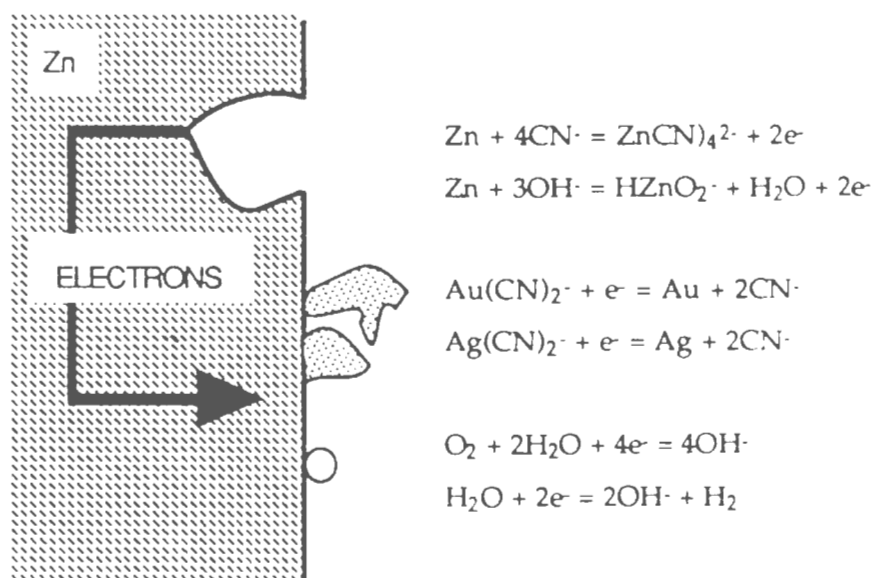
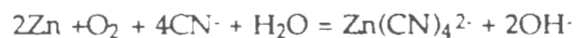
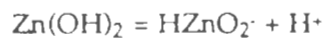
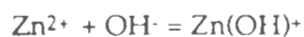

Figure 2.1. Dissolution of Zinc in Cyanide Solution.



Similar equations can also be written for silver cyanide solution.

Figure 2.1 shows the electrochemical process of zinc dissolving in gold and silver cyanide solution. In aqueous cyanide solutions, the zincic ion forms numerous complexes by reaction with cyanide and hydroxyl ions (16). Most of them are soluble except one, $\text{Zn}(\text{OH})_2$, which is sparingly soluble. The reactions are listed as follows:



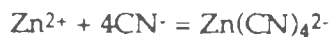

Thus, the solubility of zinc in this system should be defined as the following:

$$S = [\text{Zn}^{2+}] + \text{Zn}(\text{OH})_{2(\text{aq})} + [\text{HZnO}_2^-] + [\text{ZnO}_2^{2-}] + [\text{ZnCN}^+] + \\ + [\text{Zn}(\text{CN})_{2(\text{aq})}] + [\text{Zn}(\text{CN})_3^-] + [\text{Zn}(\text{CN})_4^{2-}]$$

2.3 Thermodynamic Considerations

The dissolution of zinc in gold or silver cyanide solution is an electrochemical process involving the oxidation of zinc and the reduction of gold or silver cyanide complexes, as well as the reduction of oxygen and water. This process will be affected by many factors, such as cyanide and the metal ion concentrations, pH value and the electrochemical potential. To understand in more detail the dissolution of zinc in cyanide solution, an Eh-pH diagram should be constructed. Table 2.4 and Table 2.5 present the thermodynamic data and the possible reactions in the Au-H₂O, Au-Zn-CN-H₂O, Ag-H₂O, Ag-Zn-CN-H₂O systems, respectively. These thermodynamic data have been obtained from Pourbaix (21), Latimer (17) and Finkelstein (16). The pressures of oxygen and hydrogen have been taken as one atmosphere,

and the activity of Zn(II) has been taken as 1.5×10^{-4} which is equivalent to a concentration of 10 ppm assuming activity coefficients of unity.

Table 2.4. Reduction potentials for Au-Zn-CN-H₂O and Au-H₂O systems at 25°C(16) (17) (21).

Reactions	$E^0(\text{V})$
$\text{AuO}_2 + \text{H}_2\text{O} + \text{H}^+ + \text{e} = \text{H}_3\text{AuO}_3$	2.630
$\text{AuO}_2 + \text{H}_2\text{O} + \text{e} = \text{HAuO}_3^{2-} + \text{H}^+$	0.822
$\text{AuO}_2 + 4\text{H}^+ + \text{e} = \text{Au}^{3+} + 2\text{H}_2\text{O}$	2.507
$\text{Au}(\text{OH})_3 + 2\text{CN}^- + 3\text{H}^+ + 2\text{e} = \text{Au}(\text{CN})_2 + 3\text{H}_2\text{O}$	2.421
$\text{Au}^{3+} + 2\text{CN}^- + 2\text{e} = \text{Au}(\text{CN})_2^-$	2.483
$\text{HAuO}_3^{2-} + 2\text{CN}^- + 5\text{H}^+ = \text{Au}(\text{CN})_2^- + 3\text{H}_2\text{O}$	3.325
$\text{Au}(\text{CN})_2^- + \text{e} = \text{Au} + 2\text{CN}^-$	-0.473
$\text{Au}^{3+} + 3\text{e} = \text{Au}$	1.498
$\text{H}_3\text{AuO}_3 + 3\text{H}^+ + 3\text{e} = \text{Au} + 3\text{H}_2\text{O}$	1.457
$\text{HAuO}_3^{2-} + 5\text{H}^+ + 3\text{e} = \text{Au} + 3\text{H}_2\text{O}$	2.059
$\text{Zn}^{2+} + 2\text{e} = \text{Zn}$	-0.763
$\text{Zn}(\text{OH})_2 + 2\text{e} = \text{Zn} + 2\text{OH}^-$	-1.276
$\text{HZnO}_2^- + 3\text{H}^+ + 2\text{e} = \text{Zn} + 2\text{H}_2\text{O}$	0.054
$\text{ZnO}_2^{2-} + 4\text{H}^+ + 2\text{e} = \text{Zn} + 2\text{H}_2\text{O}$	0.441
$\text{Zn}(\text{CN})_4^{2-} + 2\text{e} = \text{Zn} + 4\text{CN}^-$	-1.250
$\text{O}_2 + 4\text{H}^+ + 4\text{e} = 2\text{H}_2\text{O}$	1.228
$\text{H}_2\text{O} + 2\text{e} = 2\text{OH}^- + \text{H}_2$	0.000

Table 2.5. Reduction potentials for Ag-Zn-CN-H₂O and Ag-H₂O systems at 25°C(16) (17) (21).

Reactions	E ⁰ (V)
$\text{Ag}_2\text{O}_3 + 2\text{CN}^- + 6\text{H}^+ + 4e = 2\text{Ag}(\text{CN})_2 + 3\text{H}_2\text{O}$	2.115
$\text{Ag}_2\text{O}_3 + 4\text{CN}^- + 6\text{H}^+ + 4e = 2\text{Ag}(\text{CN})_2^- + 3\text{H}_2\text{O}$	2.204
$\text{Ag}(\text{CN})_2 + e = \text{Ag} + \text{CN}^-$	-0.091
$\text{Ag}(\text{CN})_2^- + e = \text{Ag} + 2\text{CN}^-$	-0.269
$\text{Ag}_2\text{O}_3 + 6\text{H}^+ + 4e = 2\text{Ag}^+ + 3\text{H}_2\text{O}$	1.670
$\text{Ag}_2\text{O}_3 + 2\text{H}^+ + 2e = 2\text{AgO} + \text{H}_2\text{O}$	1.569
$\text{AgO} + 2\text{H}^+ + 2e = \text{Ag}_2\text{O} + \text{H}_2\text{O}$	1.398
$\text{AgO} + 2\text{H}^+ + 2e = \text{Ag}^+ + \text{H}_2\text{O}$	1.772
$\text{Ag}^+ + e = \text{Ag}$	0.799
$\text{Ag}_2\text{O} + 2\text{H}^+ + 2e = 2\text{Ag} + \text{H}_2\text{O}$	1.173

2.4 Eh-pH Diagrams

Eh-pH diagrams for the Au-Zn-H₂O and Ag-Zn-H₂O systems at 25°C are shown in Figure 2.2 and Figure 2.3, respectively, with [Au] = 4 × 10⁻⁷ M and [Ag] = 2 × 10⁻⁴ M. Figure 2.4 shows the Au-Zn-CN-H₂O system at 25° C with two different cyanide concentrations, 2 × 10⁻³M and 1 × 10⁻²M. Figure 2.5 shows the Ag-Zn-CN-H₂O system at 25°C with two different cyanide concentrations, and is similar to Figure 2.4. Figure 2.6 and Figure 2.7 illustrate the effect of dissolved gold and silver concentrations with a cyanide concentration of 1 × 10⁻² M, in both cases.

In aqueous cyanide solutions, there are two cyanide species present, HCN and free CN^- (22), neglecting the cyanide combined in complex ions. Hydrocyanic acid is a very weak acid. Its dissociation affects the driving force of the reactions involving cyanide ion, so the potential varies with pH.



$$K_a = (\text{H}^+)(\text{CN}^-)/\text{HCN} = 4.93 \times 10^{-10} \quad (2.2)$$

$$(\text{CN}^-)_t = (\text{HCN}) + (\text{CN}^-) \quad (2.3)$$

$$(\text{CN}^-)/[(\text{CN}^-)_t - (\text{CN}^-)] = 4.93 \times 10^{-10}/(\text{H}^+) \quad (2.4)$$

$$(\text{CN}^-)_t/(\text{CN}^-) = 1 + (\text{H}^+)/(4.93 \times 10^{-10}) \quad (2.5)$$

$$(\text{CN}^-) = (4.93 \times 10^{-10}) \times (\text{CN}^-)_t/[4.93 \times 10^{-10} + (\text{H}^+)] \quad (2.6)$$

$$\begin{aligned} \log(\text{CN}^-) &= \log(4.93 \times 10^{-10}) - \log[4.93 \times 10^{-10} + (\text{H}^+)] + \\ &+ \log(\text{CN}^-)_t \end{aligned} \quad (2.7)$$

Comparing of Figure 2.2 with Figure 2.4, one can see that significant changes occur in the gold and silver systems when CN^- is added. The stability fields of metallic gold and silver as well as their oxides and hydroxides are reduced dramatically, especially for metallic gold and silver. From Figure 2.4 and Figure 2.5, it can be seen that the oxidation potential of $\text{Au}(\text{CN})_2^-$ decreases with an increase in the cyanide concentration and increases with an increase in the dissolved metal concentration. The behavior of silver in cyanide solution is similar to that of gold. The species, $\text{Ag}(\text{CN})_3^{2-}$, is not present in Figure 2.5 and Figure 2.7 because cyanide concentration is not

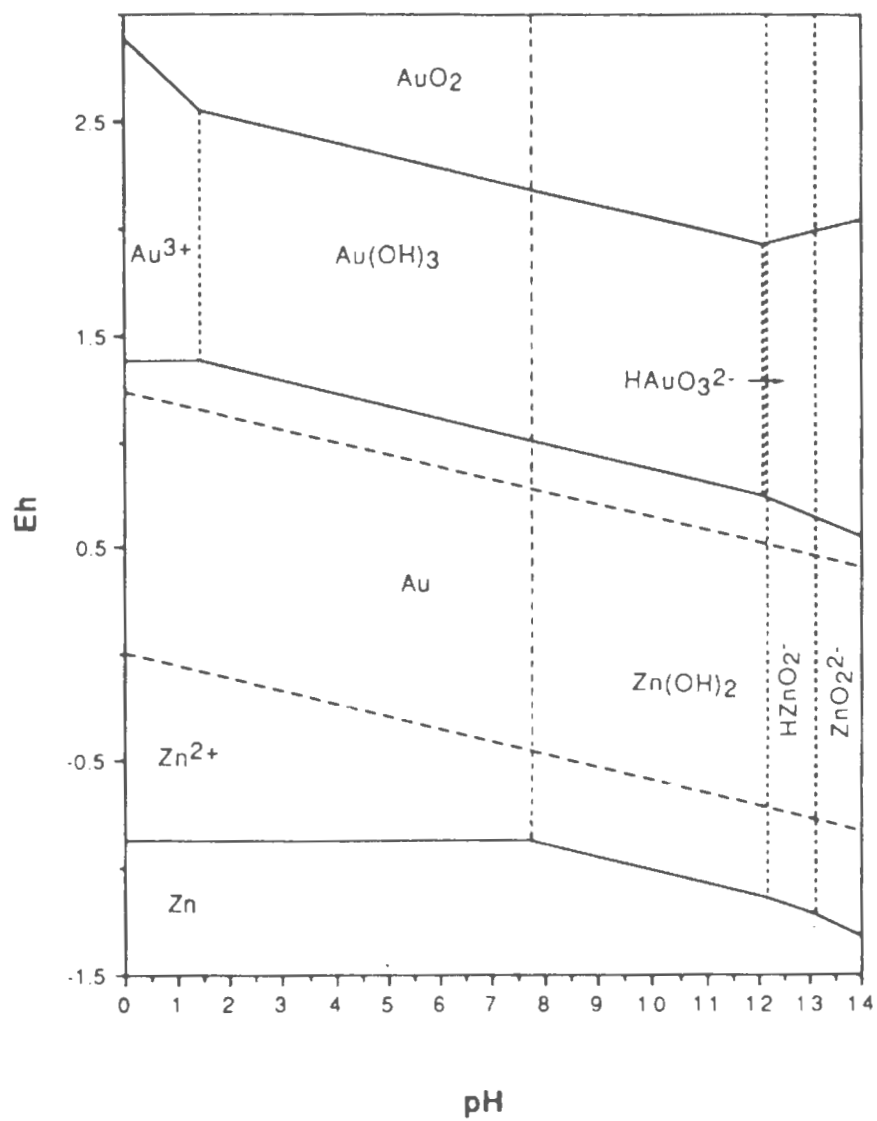

Figure 2.2. Eh-pH diagram for the Au-Zn-H₂O system at 25°C; [Au] = 4 × 10⁻⁷ mol/L.

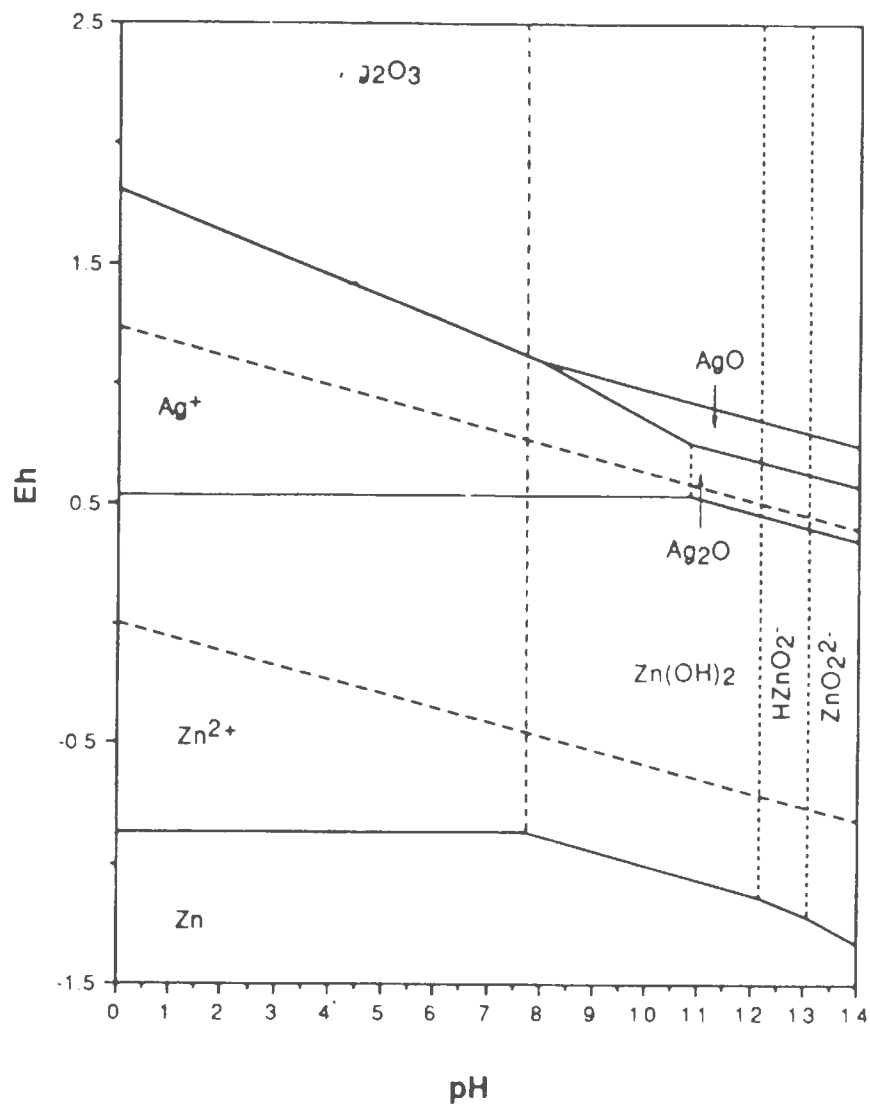

Figure 2.3. Eh-pH diagram for the Ag-Zn-H₂O system at 25°C; [Ag] = 2.5 × 10⁻⁴ mol/L.

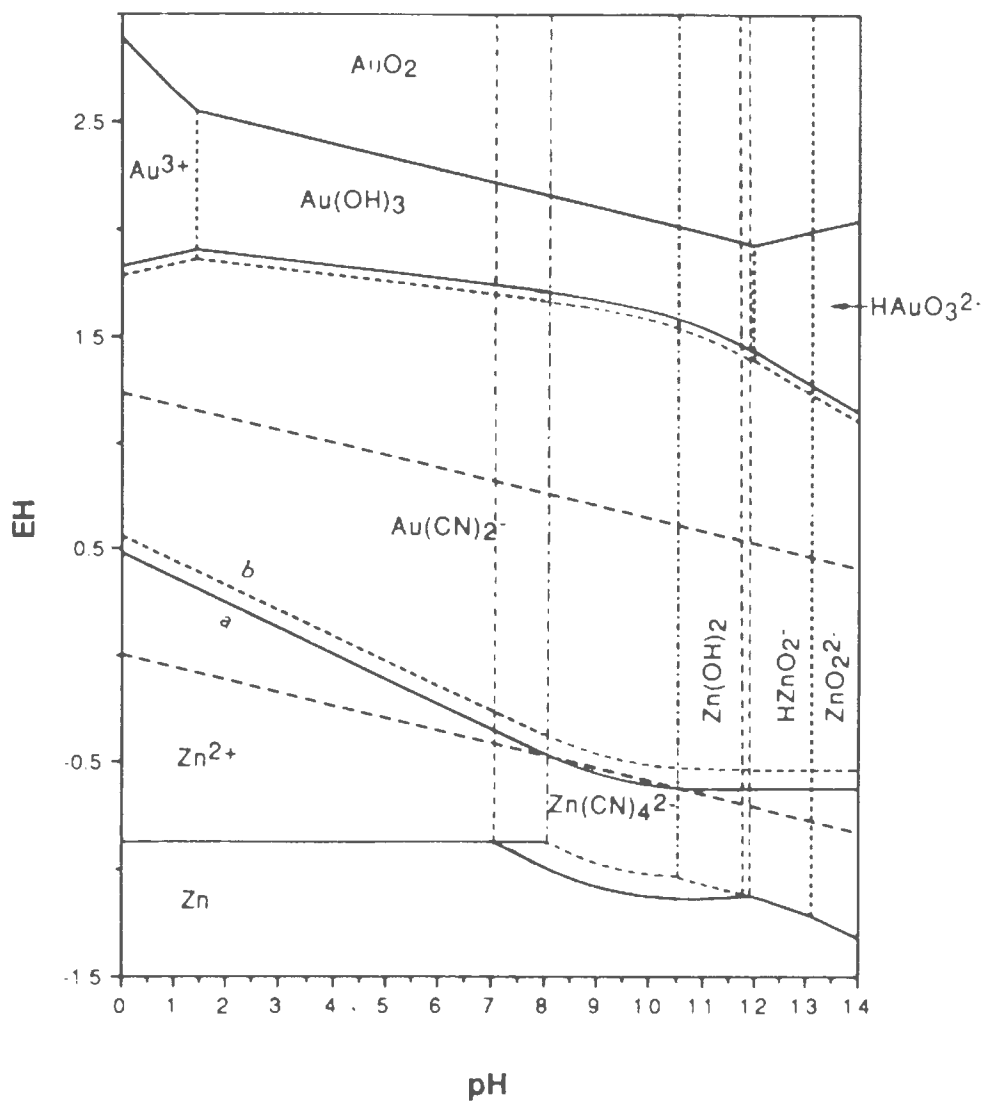

Figure 2.4. Eh-pH diagram for the Au-Zn-CN-H₂O system at 25°C with different cyanide concentrations; [Au] = 4 × 10⁻⁷ mol/L; (a) [CN] = 10⁻² mol/L; (b) [CN] = 2 × 10⁻³ mol/L.

sufficiently high for it to form. $\text{AgCN}_{(s)}$ appears only in the low pH regions. At pH values greater than the pK_a , the only stable silver complex is $\text{Ag}(\text{CN})_2^-$ when the cyanide concentration is 1×10^{-2} or 2×10^{-3} M.

Zinc dissolves in gold cyanide or silver cyanide solution reacting with cyanide and hydroxyl ions as shown in the Eh-pH diagrams. Of the various oxidized forms, Zn^{2+} , $\text{Zn}(\text{CN})_4^{2-}$, $\text{Zn}(\text{OH})_2$, HZnO_2^- and ZnO_2^- , the formation of zinc hydroxide precipitate is highly undesirable, since it is the only one that is sparingly soluble. It is thought to coat the zinc surface, causing passivation and inhibition of further reaction. The region of predominance of zinc hydroxide is dependent on the cyanide concentration, that is, increasing cyanide concentration reduces the zinc hydroxide predominance region. All of the figures show that the oxidation of zinc takes place at lower potentials than the oxidation of both gold and silver, no matter which oxidized form of zinc is predominant. That means, at all pH values, elemental zinc will not be stable in the presence of $\text{Au}(\text{CN})_2^-$ or $\text{Ag}(\text{CN})_2^-$. Zinc will tend to reduce the gold and silver and, itself, be oxidized. Furthermore, zinc is sufficiently strongly reducing to reduce water to hydrogen at all pH values. As a result the dissolution and consumption of zinc occurs by several different mechanisms.

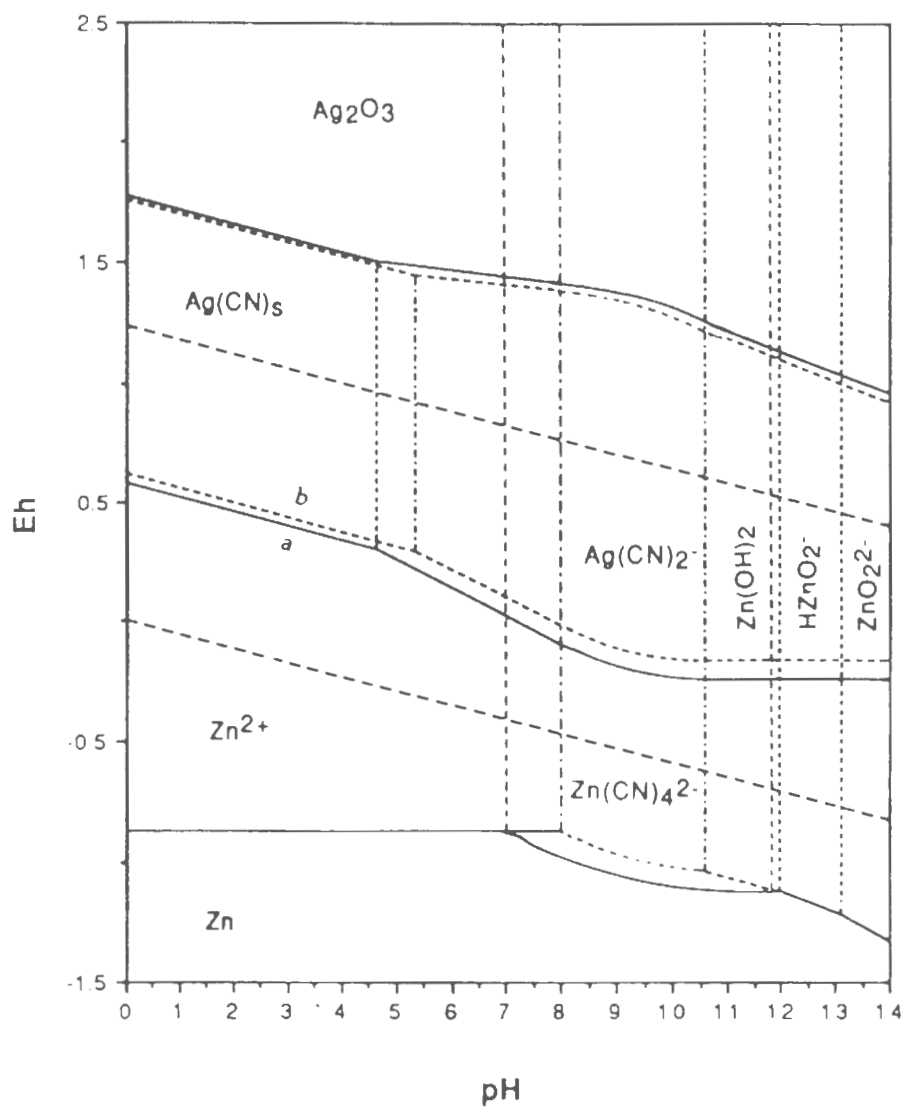

Figure 2.5. Eh-pH diagram for the Ag-Zn-CN-H₂O system at 25°C with different cyanide concentrations; $[\text{Ag}] = 2.5 \times 10^{-4}$ mol/L; (a) $[\text{CN}] = 10^{-2}$ mol/L; (b) $[\text{CN}] = 2 \times 10^{-3}$ mol/L.

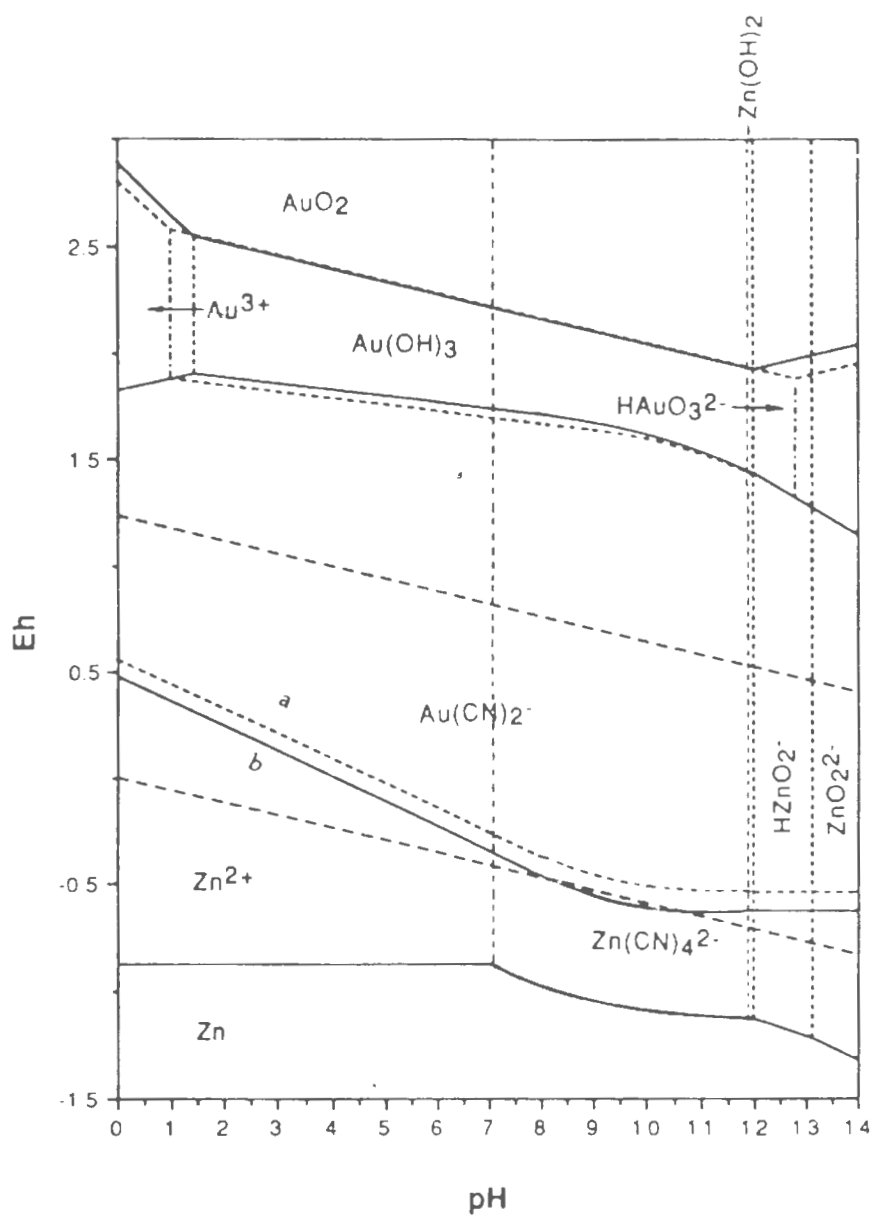

Figure 2.6. Eh-pH diagram for the Au-Zn-CN-H₂O system at 25°C with different dissolved gold concentrations; [CN] = 10⁻² mol/L; (a) [Au] = 4 × 10⁻⁷ mol/L; (b) [Au] = 10⁻⁵ mol/L.

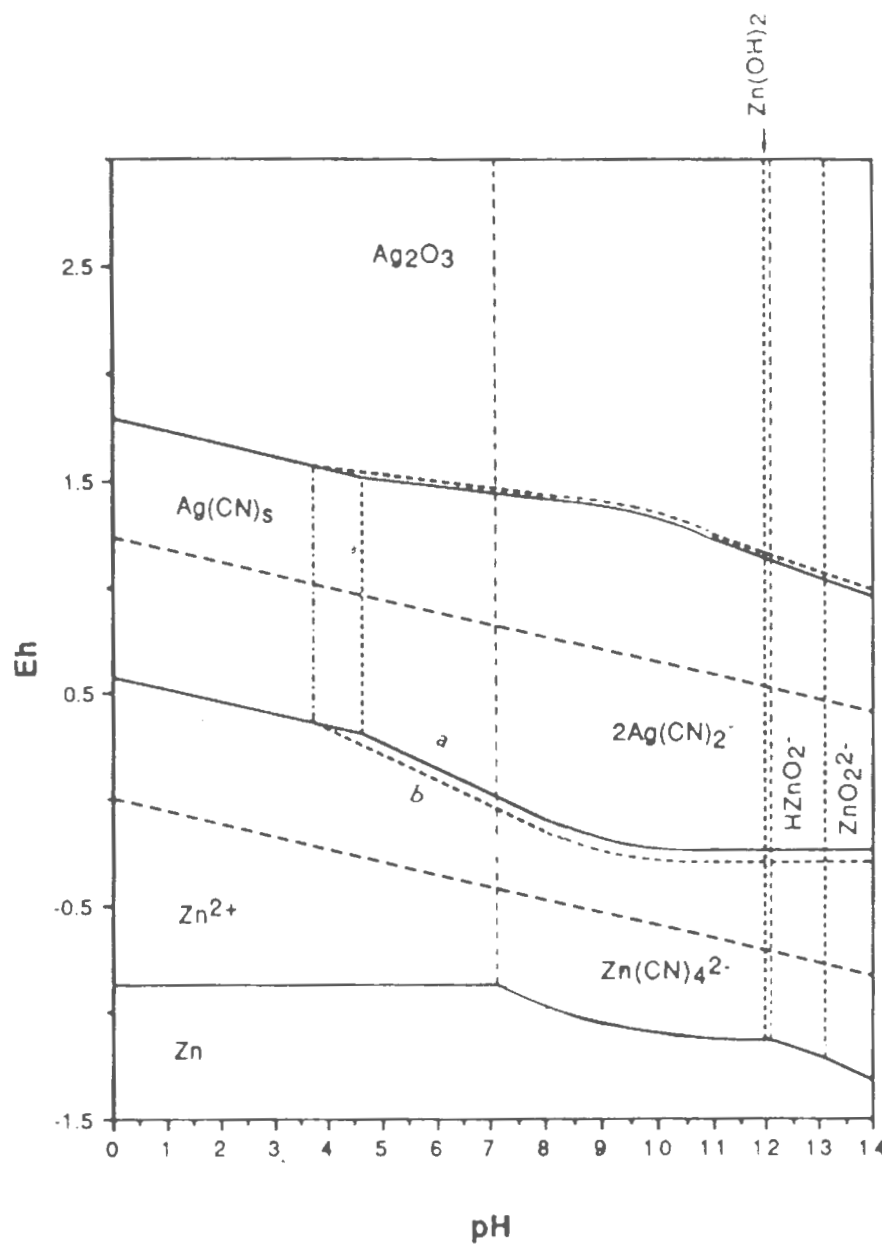

Figure 2.7. Eh-pH diagram for the Ag-Zn-CN-H₂O system at 25°C with different dissolved silver concentrations; [CN] = 10⁻² mol/L; (a) [Ag] = 2.5 × 10⁻⁴ mol/L; (b) [Ag] = 3 × 10⁻⁵ mol/L.

3. EXPERIMENTAL APPARATUS AND PROCEDURES

3.1 Materials

The materials used in the investigation are listed in Table 3.1.

Table 3.1. Materials Employed.

Material	Source
Merrillite zinc dust	Pasco Zinc Corp.
Reagent-grade sodium cyanide	Fisher Scientific
Reagent-grade sodium hydroxide	Fisher Scientific
Reagent-grade lead nitrate	Fisher Scientific
Standard zinc solution	Fisher Scientific
Gold (I) cyanide	Aldrich Chemical Company
Silver (I) cyanide	Aldrich Chemical Company

3.2 Apparatus

All of the experiments were conducted in a four-necked 500 ml glass reaction cell. Inserted into the four orifices of the reactor are a dissolved oxygen probe, a nitrogen dispersion tube, a sampling device, and zinc and lead nitrate addition tubes. See Figure 3.1.

The solution in the reaction cell was agitated by a magnetic stir bar, and all of the experiments were conducted at room temperature (22°C).

A desired concentration of dissolved oxygen was effected by dispersion of nitrogen through the solution. Dissolved oxygen in solution was measured by a YSI Model 58 dissolved oxygen meter. The pH of the solution was

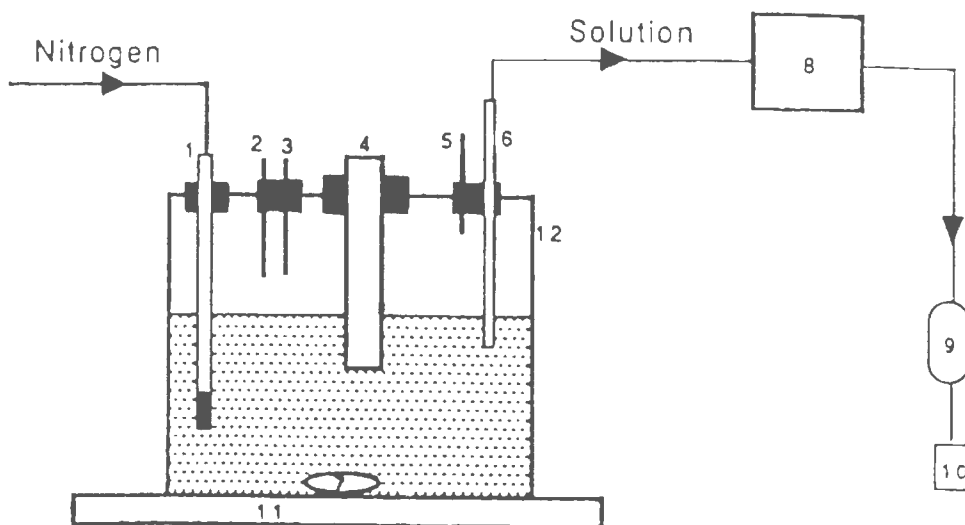

Figure 3.1. Schematic diagram of experimental apparatus.

1. Gas dispersion tube
2. Transfer tube for adding zinc dust
3. Transfer tube for adding lead nitrate
4. Oxygen meter probe
5. Tube for air escape
6. Glass tube for solution withdrawal
7. Magnetic stir bar
8. Pump
9. Filter
10. Sample bottle
11. Magnetic stirrer
12. Reaction vessel

measured with an Accumet Model 910 pH Meter. The pH of the test solution, which was prepared with reagent-grade NaCN, was adjusted with reagent-grade NaOH. All solutions were prepared with distilled water.

3.3 Experimental Conditions

The following experimental conditions, which are those commonly experienced in practice, were selected for this study.

NaCN:	1.5 x 10 ⁻⁴	0.1	0.5	(g/L)
Oxygen:	0.2	0.5	1.0	1.5 (ppm)
Gold:	0.1	0.5	2.0	(ppm)
Silver:	5.0	20.0	40.0	(ppm)
Lead Nitrate:	0.0	10.0		(ppm)
Zinc:	18			(mg/L)
Volume of Solution:	500			(mL)
Temperature:	20 - 24°C			

3.4 Experimental Procedures

The procedures for the entire experiment are described as follows:

Preparations

- * Solutions were prepared at pH 10.5 with the desired NaCN concentration.

- * Solutions were transferred from a 500 ml flask to the reaction vessel.
- * The desired amount of $\text{Au}(\text{CN})_2^-$ or $\text{Ag}(\text{CN})_2^-$ were placed inside the reaction vessel.
- * 9 mg of zinc dust was weighed in a polyplug.
- * 5 mg of lead nitrate was weighed in a polyplug.
- * The above polyplugs were placed into two separate transfer tubes.
- * A stir bar was placed in the reaction vessel.
- * All the openings were capped with rubber stoppers.

Conducting the Experiment

- * The solution was purged with gas at a constant flow rate for about 15 minutes.
- * The solution was stirred for 5 minutes.
- * The rubber tubing was clamped.
- * Stirring was stopped.
- * Purging with nitrogen gas was continued for 1 minute more.
- * The oxygen meter probe was placed into the solution.
- * Purging with nitrogen gas was stopped.
- * The oxygen concentration was measured with the oxygen probe.
- * When the reading was stable, the zinc and lead nitrate were added.
- * The solution was stirred again until the reaction reached equilibrium.

- Stirring was stopped.
- The pump used to withdraw solution from the reaction vessel through a filter to the sample bottle was turned on.
- The solution was analyzed at wavelength 2139 Å using an Atomic Absorption Spectrometer (PERKIN-ELMER, Model 2380).

4. RESULTS AND DISCUSSION

Experiments were conducted to establish the reproducibility of the experiments. A series of experiments were conducted at three different times. The results are shown in Table 4.1.

Table 4.1. Experimental Reproducibility.

Conditions: 0.1 g/L NaCN, 0.5 ppm O ₂ , [Au] = 0.1 ppm, pH 10.7, 22°C.	
Experiment	Solubility of Zinc, ppm
1	7.0
2	6.6
3	6.6
Conditions: 0.1 g/L NaCN, 0.5 ppm O ₂ , [Au] = 0.5 ppm, pH 10.7, 22°C.	
Experiment	Solubility of Zinc, ppm
1	7.2
2	7.4
3	7.7
Conditions: 0.1 g/L NaCN, 0.5 ppm O ₂ , [Au] = 2.0 ppm, pH 10.7, 22°C.	
Experiment	Solubility of Zinc, ppm
1	8.0
2	8.3
3	7.9

4.1. Cyanide Concentration

Insufficient free cyanide in solution is a problem encountered very often in Merrill-Crowe processing. This can be one of the reasons for the high barren solutions sometimes obtained. From a theoretical point of view, the cyanide concentration can influence the zinc solubility from both thermodynamic and kinetic aspects. Figure 2.4 and Figure 2.5 show clearly that the Eh values for the reactions:



will increase when the free cyanide concentration is decreased, and that the increase in Eh values for these three reactions will be similar with the same decrease in free cyanide concentration. As a result, the cyanide concentration does not exhibit a large effect on the reaction driving force in this system. From Figures 2.4 and 2.5, we also note that zinc hydroxide can form and adsorb on the surface of metallic zinc. When the amount of Zn(OH)_2 formed during the reaction exceeds a certain critical value, the precious metal cementation reaction is retarded and may even stop.

The reactions which most accurately describe the stoichiometry of the precious metal precipitation reactions in the Merrill-Crowe system are:

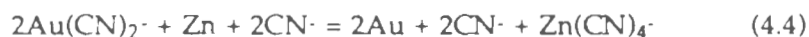

The free cyanide species, CN^- , in reactions (4.4) and (4.5) is involved in the kinetics of these reactions.

Figure 4.1 shows the solubility of zinc in the Au-Zn-CN- H_2O system with 0.1 g/L and 0.5 g/L NaCN in solution. From these results one can see that in alkaline cyanide solution, the solubility of zinc increases with an increase in free cyanide concentration due to the prevention of the formation of $\text{Zn}(\text{OH})_2$ and the formation of $\text{Zn}(\text{CN})_4^{2-}$.

At low cyanide concentration, the solubility of zinc is very low and is independent of oxygen concentration. Figure 4.2 shows this phenomena very

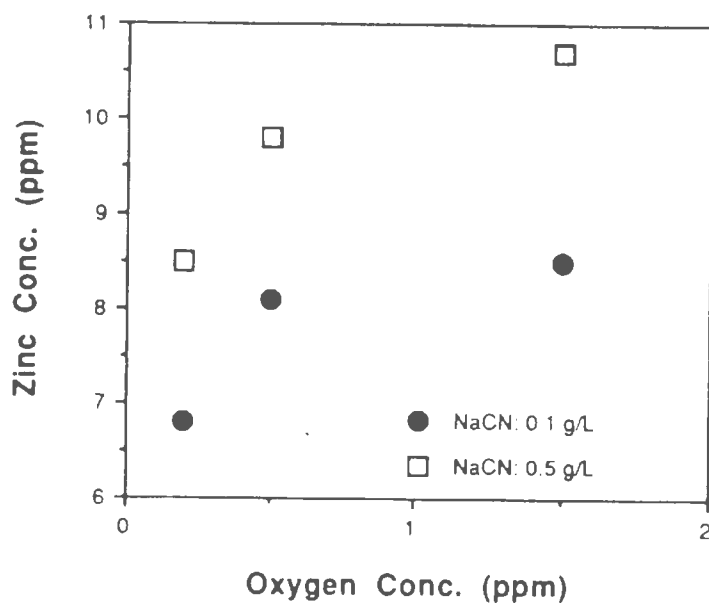

Figure 4.1. Effect of cyanide concentration on zinc solubility in gold cyanide systems; $[\text{Au}] = 2 \text{ ppm}$, $\text{pH } 10.7$, 22°C .

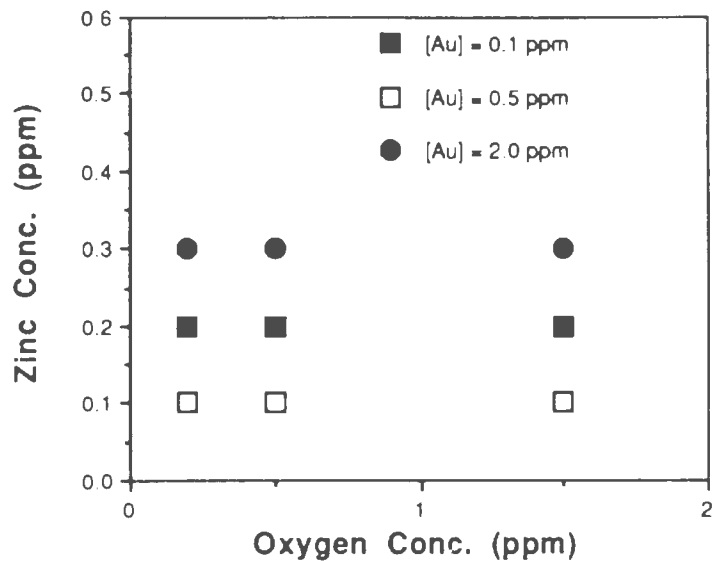

Figure 4.2. Solubilities of zinc in low cyanide concentration solution; $[\text{NaCN}] = 1.5 \times 10^{-4}\text{M}$, pH 10.7, 22°C.

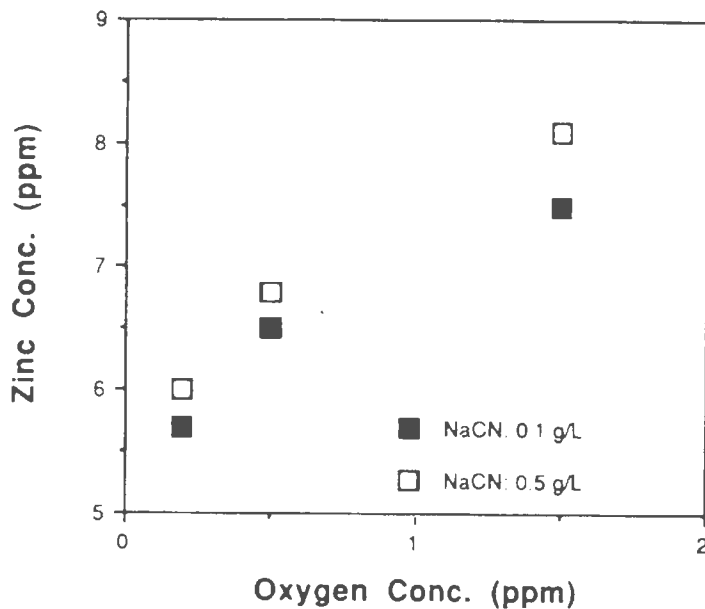

Figure 4.3. Effect of cyanide concentration on zinc solubility in silver cyanide systems; $[\text{Ag}] = 5\text{ ppm}$, pH 10.7, 22°C.

clearly. The cyanide concentration in this case is only 1.5×10^{-4} M. In a solution like this, zinc hydroxide forms and adsorbs at the zinc surface, preventing access of reactants to or removal of reaction products from the surface.

The effect of free cyanide concentration in the Ag-Zn-CN-H₂O system is similar to that obtained when gold is present. See Figure 4.3.

4.2 Oxygen Concentration

Dissolved oxygen reacts with zinc in cyanide solution according to the reaction:



The presence of dissolved oxygen, then, is very important in zinc consumption. The reduction of oxygen competes with the reduction of gold or silver and retards the precipitation reaction. Figures 4.4-4.7 indicate that the solubility of zinc increases with increasing concentration of dissolved oxygen in both the Au-Zn-CN-H₂O and the Ag-Zn-CN-H₂O systems. At the lower concentrations of gold and silver ion, the efficiency of cementation is low. Almost all of the soluble zinc is due to the oxidation of metallic zinc by oxygen and water. As a result, increasing the initial dissolved oxygen concentration only contributes to zinc consumption with little or no effect on the efficiency of cementation. For higher concentrations of precious metal

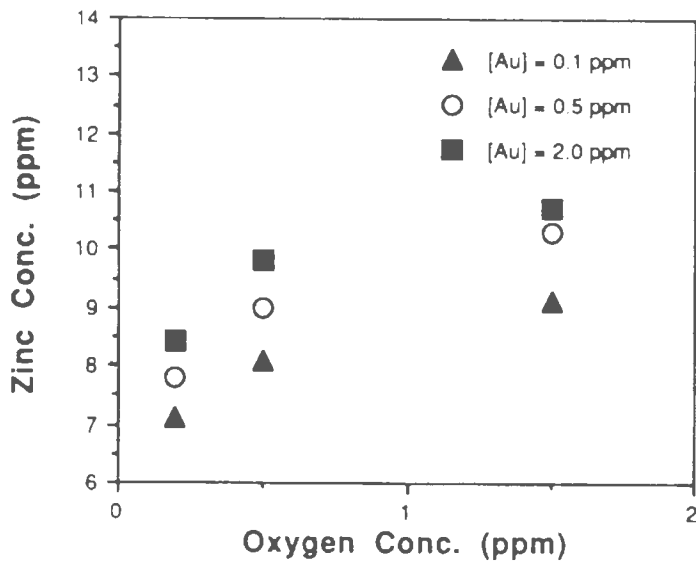

Figure 4.4. Effect of initial dissolved oxygen concentration on zinc solubility; [NaCN] = 0.5 g/L, pH 10.7, 22°C.

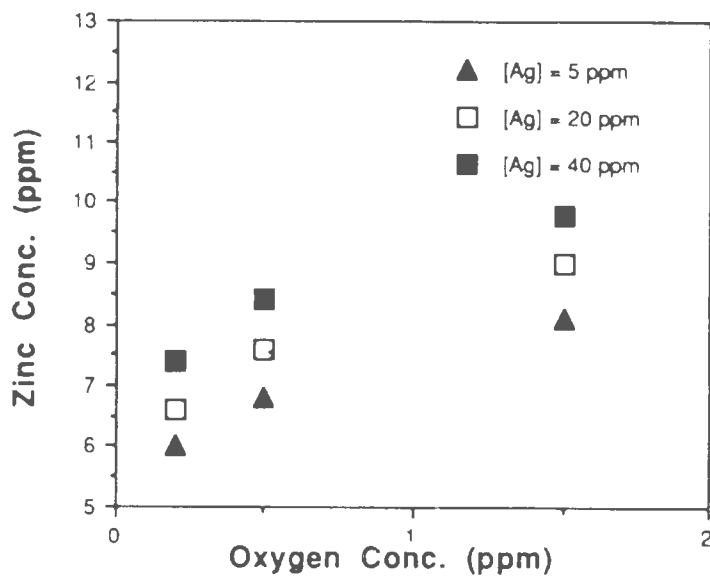

Figure 4.5. Effect of initial dissolved oxygen concentration on zinc solubility; [NaCN] = 0.5 g/L, pH 10.7, 22°C.

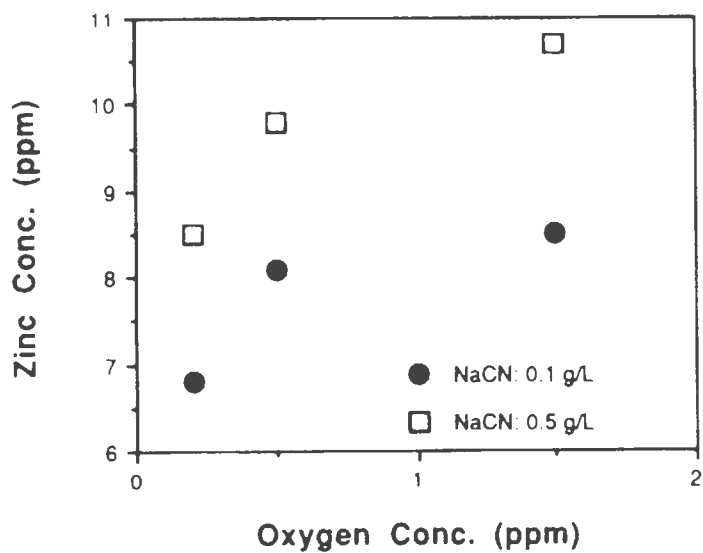

Figure 4.6. Effect of initial dissolved oxygen concentration on zinc solubility; [Au] = 2 ppm, pH 10.7, 22°C.

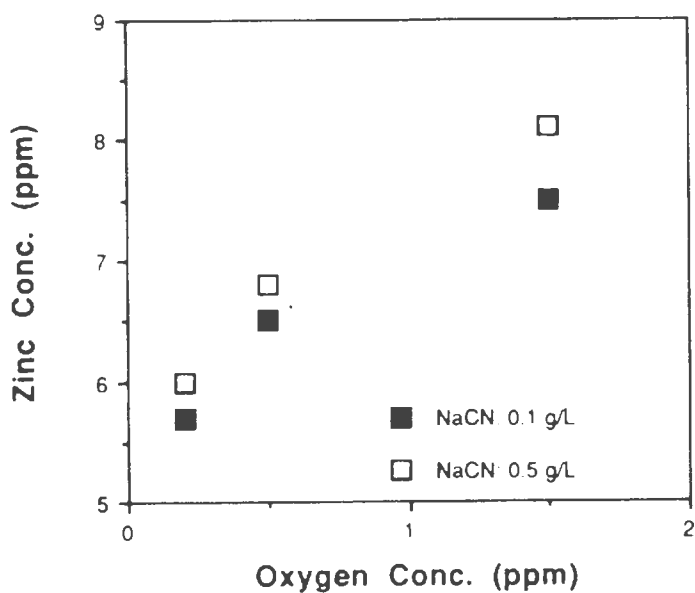

Figure 4.7. Effect of initial dissolved oxygen concentration on zinc solubility; [Ag] = 5 ppm, pH 10.7, 22°C.

ion, obviously, efficiency increases because the higher concentrations of precious metal provide more favorable competition of dissolved gold or silver with oxygen and water for reduction. However, redissolution of precious metal would occur when the concentration of both precious metal ion and oxygen are high. The reaction then proceeds as in cyanide leaching:



In this study, redissolution of gold with high concentrations of $\text{Au}(\text{CN})_2^-$ and dissolved oxygen was observed. The amount of gold precipitate obtained for the system with 2.5 ppm dissolved oxygen was significantly less than that obtained with 0.5 ppm dissolved oxygen.

Evidence has been put forward to show that completeness of precipitation is enhanced by a small concentration (less than 1 ppm) of oxygen(23). This can be attributed to a depolarizing action at cathodic areas of the zinc surface by reaction with hydrogen as it is evolved and, therefore, is beneficial to cementation. Halbe(24) found that the amount of oxygen dissolved in a typical pregnant leach solution is commonly reduced to about 0.5 ppm by the Crowe vacuum.

4.3. Gold and Silver Concentrations

In this work, the solubility of zinc in the Merrill-Crowe system was

found to be sensitive to precious metal ion concentration, and the sensitivity was found to change with different chemical conditions. The effects of metal ion concentrations were determined at different oxygen concentrations. Figures 4.8 (a) and (b) present the relationship between zinc solubility and initial $\text{Au}(\text{CN})_2^-$ concentration at two different cyanide concentrations. Figures 4.9 (a) and (b) show the relationship between zinc solubility and initial $\text{Ag}(\text{CN})_2^-$ concentration at two different cyanide concentrations. The results shown in these two figures, Figure 4.8 and Figure 4.9, indicate that the solubility of zinc in the Merrill-Crowe system increases with an increase in initial precious metal ion concentration provided that this concentration is relatively low. The explanation for this may be due to one of two phenomena; Nicol et al.(6) found in dilute gold solution that the reaction is controlled by the mass transport of gold cyanide species to the zinc surface. Figure 4.10 illustrates this effect. A second explanation may be the effect of deposition of gold or silver. When gold or silver precipitates at the surface of zinc, this contact forms a cathodic member of a local electrochemical cell. The effect of oxygen and hydrogen will be to dissolve preferentially the more anodic zinc, especially for hydrogen due to the large exchange current densities for the hydrogen reduction reaction on the gold and silver, especially for gold. The reduction of precious metal ion will compete with oxygen and hydrogen, and however will suppress their reduction when gold or silver covers all of the surface of the zinc.

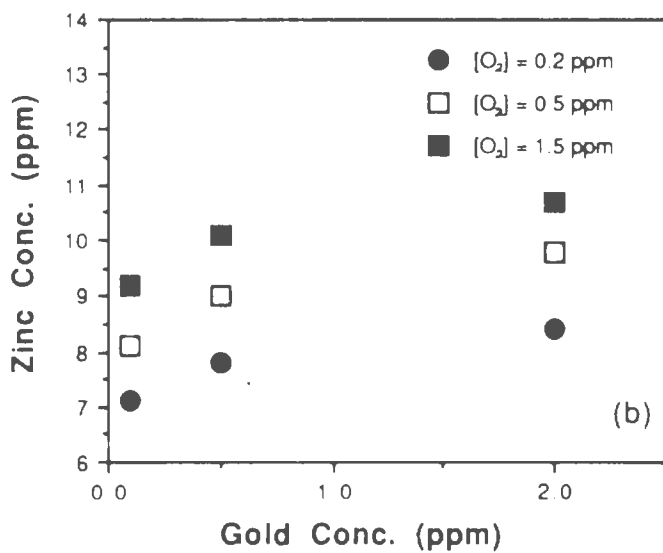
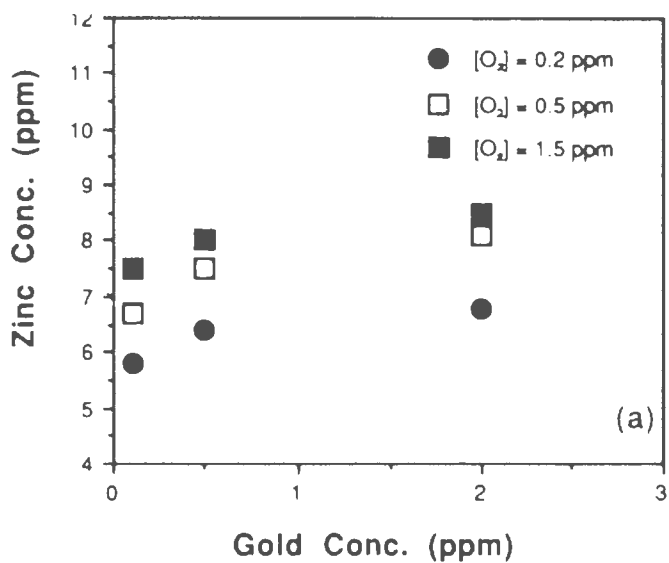

Figure 4.8. Effect of gold ion concentration on zinc solubility; pH 10.7, 22°C, (a) [NaCN] = 0.1 g/L, (b) NaCN = 0.5 g/L.

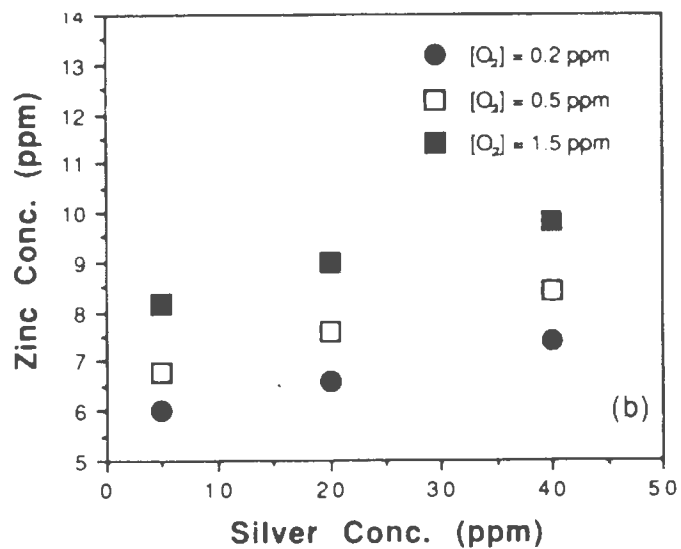
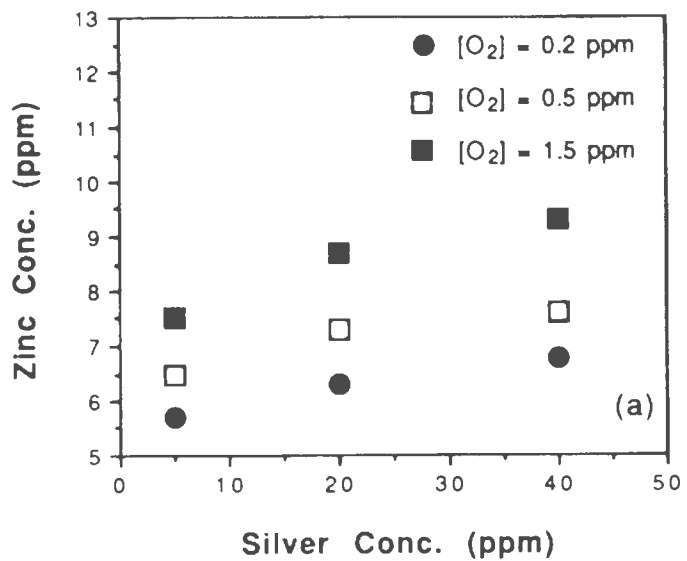

Figure 4.9 Effect of silver ion concentration on zinc solubility; pH 10.7, 22°C, (a) [NaCN] = 0.1 g/L, (b) [NaCN] = 0.5 g/L.

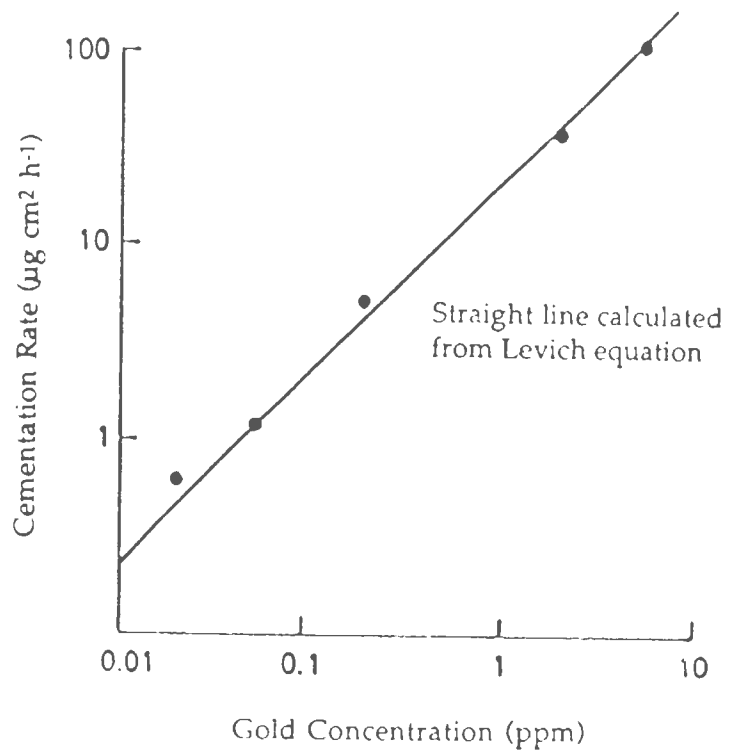

Figure 4.10. The effect of gold concentration on the rate of cementation (6).

Chi(12) has reported data on the solubility of zinc in cyanide solution in the absence of precious metal ions; some of these results are shown in Figure 4.11. A comparison of these results with zinc solubility in alkaline cyanide solution in the presence of precious metal ion may be seen in Figures 4.12 and 4.13.

At low NaCN concentration (0.1g/L), the solubility of zinc is increased significantly in the presence of relatively small concentrations of precious metal (e. g., 5 ppm Ag or 0.1 ppm Au) in comparison to that obtained in the absence of dissolved precious metal ion. This fact is due to the deposition of the gold or silver on the zinc surface which apparently enhances the reduction of water, thereby increasing the solubility of zinc. Further, the deposition of metals would inhibit the formation of zinc hydroxide on the surface.

At high oxygen concentration level, the effect of oxygen on solubility of zinc is much more pronounced than at low oxygen level. Under these conditions, the solubility of zinc is established predominantly by the reduction of oxygen. From these phenomena, one may assume that the reduction reaction of this system is a competing process. At low oxygen levels, the reduction of water is predominant, while at high oxygen levels, the reduction of oxygen is predominant. From Figure 4.12(a) and Figure 4.13(a), we can note that the solubility of zinc increases moderately as gold concentration increases from 0 to 2 ppm and silver concentration increase from 0 to 5 ppm.

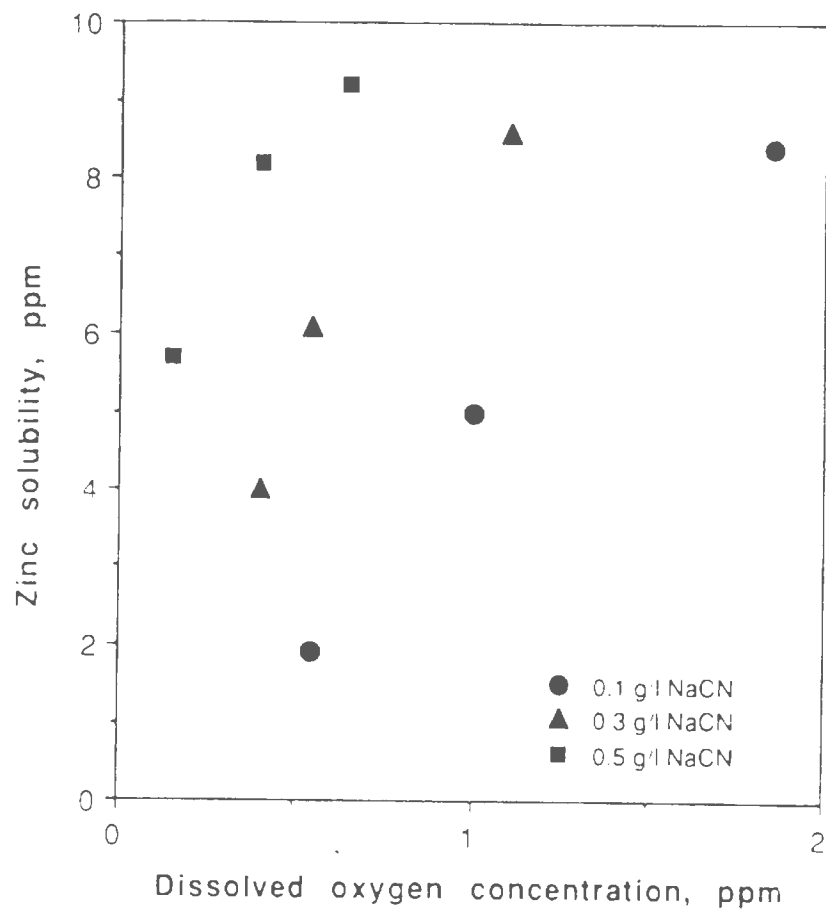

Figure 4.11. Effect of initial dissolved oxygen concentration on zinc solubility; pH 10.9, 22°C (12).

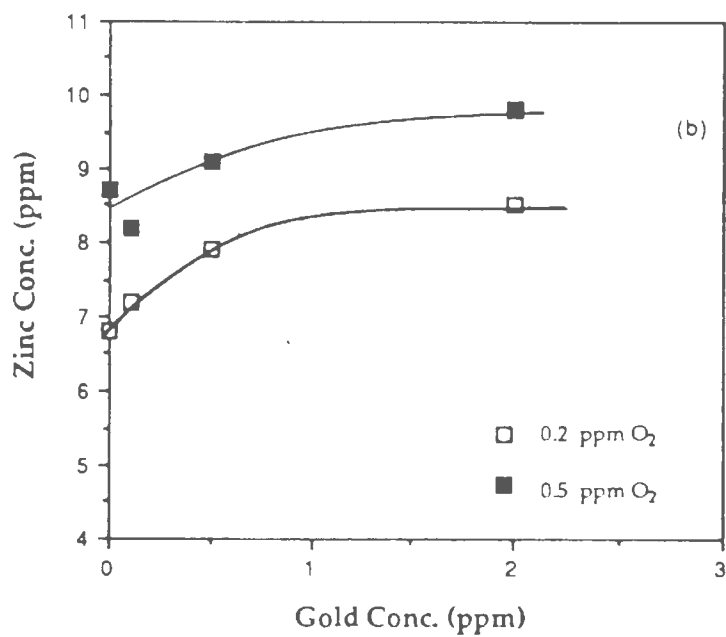
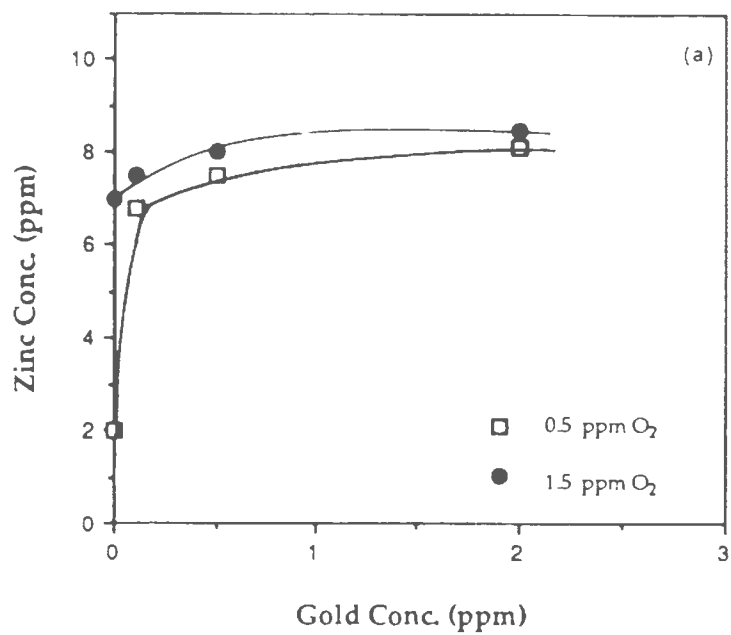

Figure 4.12. Solubility of zinc as a function of gold concentration. (a) NaCN 0.1 g/L, (b) NaCN 0.5 g/L.

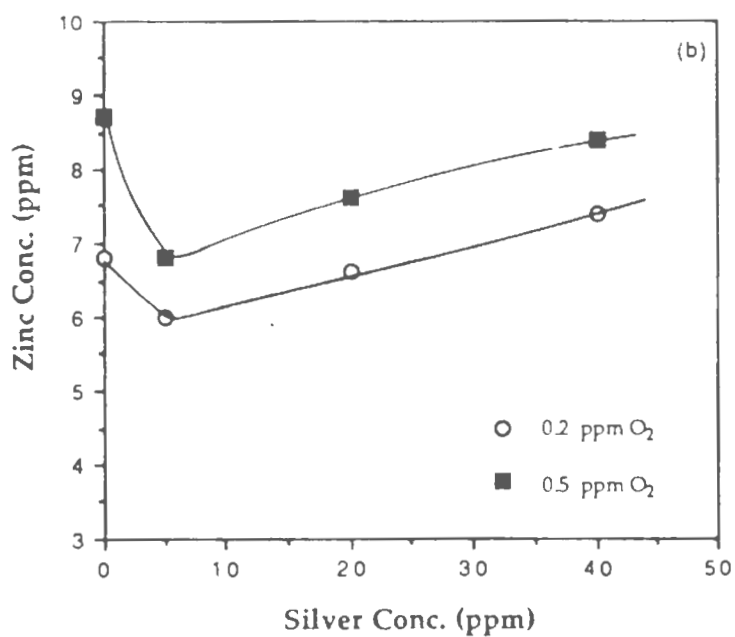
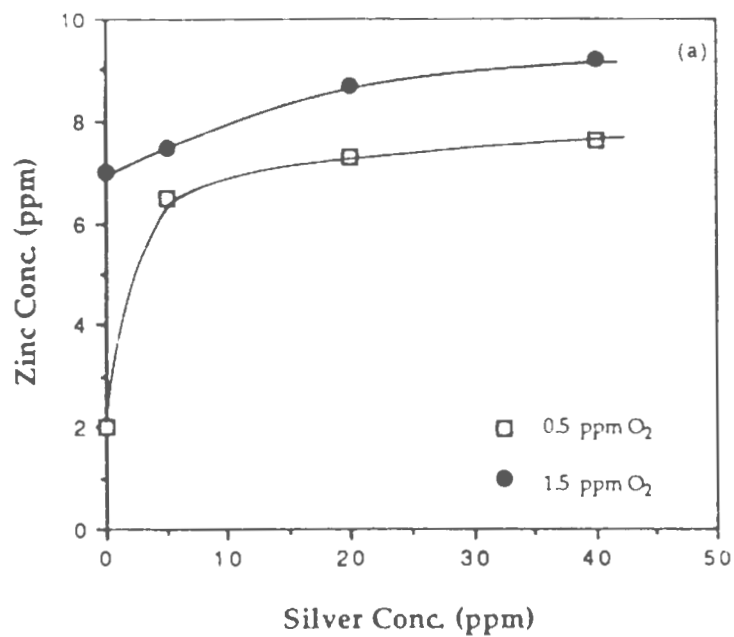

Figure 4.13. Solubility of zinc as a function of silver concentration. (a) NaCN 0.1 g/L, (b) 0.5 g/L.

When the cyanide level is increased to a higher value, e. g. 0.5 g/L, there is a difference on the effects on the solubility of zinc between gold and silver. Figure 4.12(b) shows solubility of zinc at relatively high cyanide concentration both in the absence and presence of gold. Only a small change was found in the solubility of zinc when a small amount of gold is present in the solution. But when 5 ppm silver is present in the cyanide solution, the solubility of zinc decreased in comparison to that obtained in the alkaline cyanide solution only. The precipitation rate of silver is known to be between three and four times as fast as gold due to the greater over-potential for the reaction(25). It would take a much shorter time for a silver deposit to cover all of the surface of the zinc, and this would suppress the reduction of oxygen and water. So, in the presence of some certain amount of dissolved silver, the solubility of zinc is lower than the solubility of zinc in the gold cyanide system, and is even lower than in alkaline cyanide system in the absence of silver.

4.4. Lead Nitrate Addition

It has been known for a long time that the addition of lead nitrate has a beneficial effect on the precipitation of gold and silver. Several mechanisms have been proposed, but the reasons for this enhancement are not completely understood.

Leblanc (2) has suggested that when a lead salt is added, Pb^{2+} is reduced

at the zinc surface forming cathodically-charged areas of metallic lead. The negatively-charged gold cyanide species are thought to be reduced preferentially at these polarized regions. This would help to localize gold deposition, preventing the entire surface of zinc from becoming coated with gold and allowing continued corrosion of zinc. This mechanism is shown in Figure 4.14 and 4.15.

The overpotential for hydrogen evolution on lead is very high(26). The current-potential curves for the cathodic reduction of gold cyanide onto a gold rotating disc electrode were determined at different lead concentrations(27). From Figure 4.16, the effect of increasing lead concentration from 0 to 10 ppm is clearly shown. When lead is added to the solution, the hydrogen evolution reaction is shifted in a more cathodic direction, and the reaction of gold deposition is shifted in a more anodic direction.

Some researchers have found that the structure of the gold and silver deposits is sensitive to small additions of lead. Parga et al.(11) reported that the deposit of silver formed on the zinc surface changed from a uniform layer to a dendritic, cluster deposit. The cluster deposit on the zinc surface will lead to an enhancement in the reaction kinetics. Scanning electron microscope studies conducted by Oo et al.(27) on a metallic gold area on a zinc surface revealed the formation of different types of deposits. They found the deposit formed from a 500 ppm Au solution to be complete coverage of the zinc surface by gold crystals. With 3 ppm lead addition, the deposit was in the form of clusters. For a lower gold concentration, 50 ppm, in the presence of

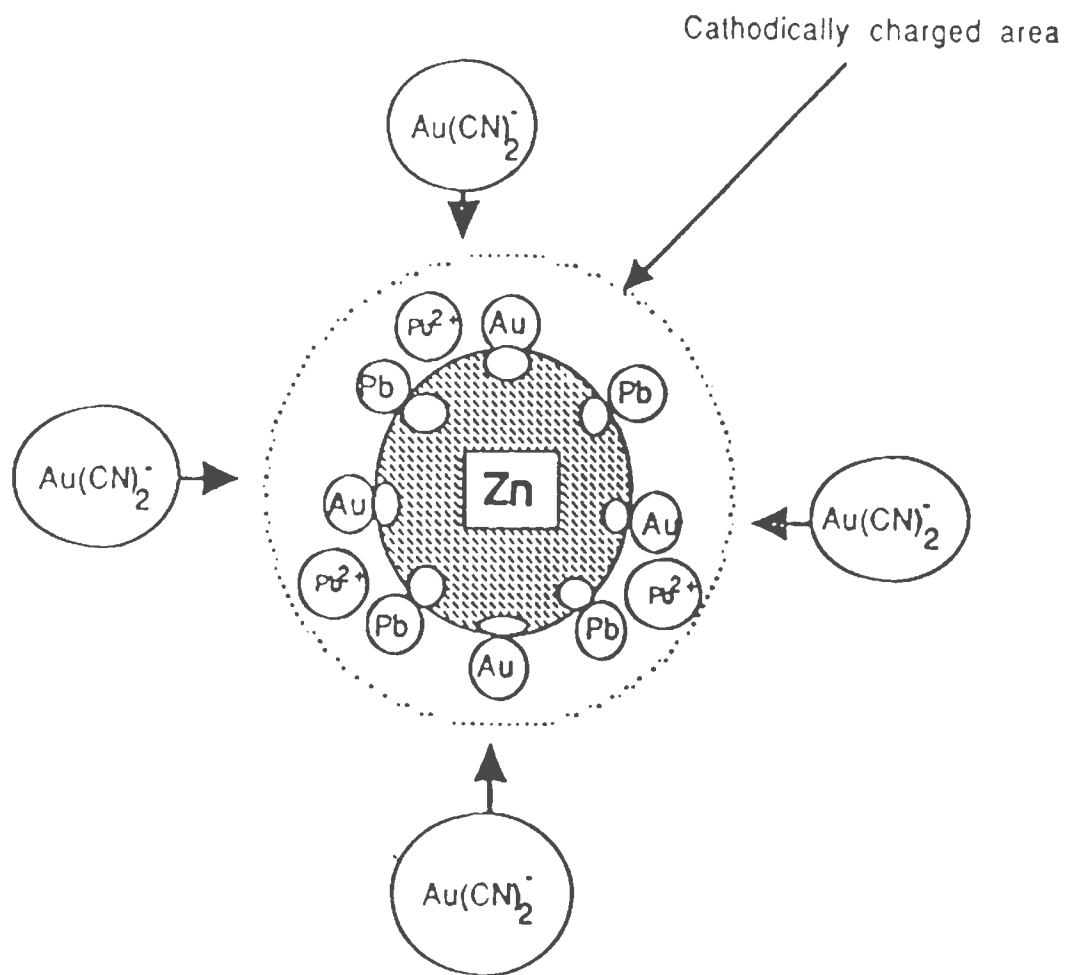

Figure 4.14. Schematic of gold precipitation on a zinc surface with lead salt addition (12).

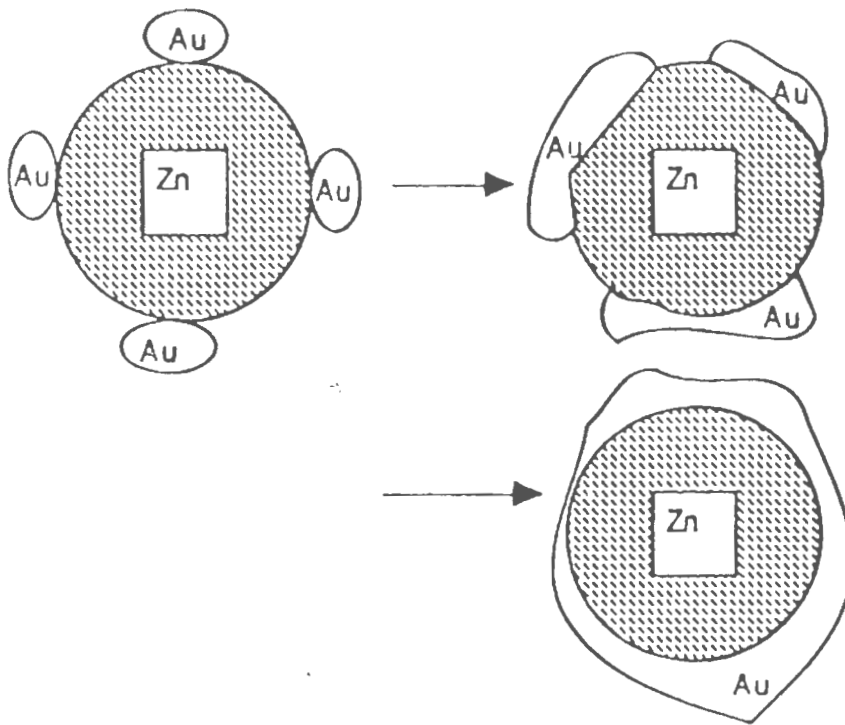

Figure 4.15. Schematic of gold precipitation on a zinc surface without lead salt addition (12).

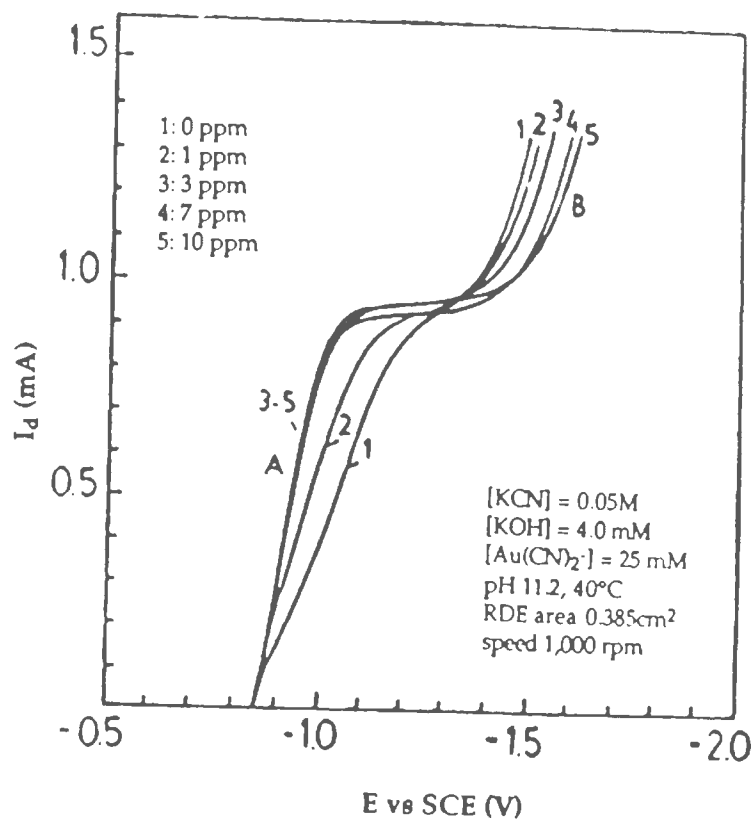

Figure 4.16. Current-potential scans for gold reduction from a solution of 0.05M KCN, 4mM KOH showing the effect of lead additions from 0 to 10 ppm (27).

lead, complete surface coverage only was observed.

Cementation is retarded or stopped by the formation of a passivating layer of zinc hydroxide at low cyanide concentration, as mentioned in Section 4.1. Lead can reduce this inhibiting effect by reducing the formation of zinc hydroxide. Figure 4.17 shows the ratios of cathodic area, A_c , to anodic area, A_a , in the $\text{Au}(\text{CN})_2^-/\text{Zn}$ system in the presence and absence of lead. The anodic area decreases dramatically after several minutes of reaction when no lead is present in solution. However, in the presence of lead, the relative decrease in the anodic area is not as great. At the same time, the zinc anodic polarization curve is shifted to a higher level. In an extreme case, the passivation current is increased by an order of magnitude as shown in Figure 4.18

An excess of lead salt is to be avoided because the zinc becomes coated with sufficient lead to retard or even stop the cementation reaction. Chi et al.(12) reported recently that zinc particles are easily coated with lead deposits at high levels of lead nitrate addition. With 15 - 20 ppm lead nitrate addition, the solubility of zinc is maximum at low cyanide concentration.

The type of deposit of gold and silver was investigated utilizing a scanning electron microscope, SEM, and different types of deposits were found for gold and silver, as shown in Figure 4.19 (a) and (b) and Figure 4.20 (a) and (b). A change in the deposit morphology was found only with silver; no difference was distinguished in gold deposits with and without lead addition. Probably, that means that the behavior of lead in these different

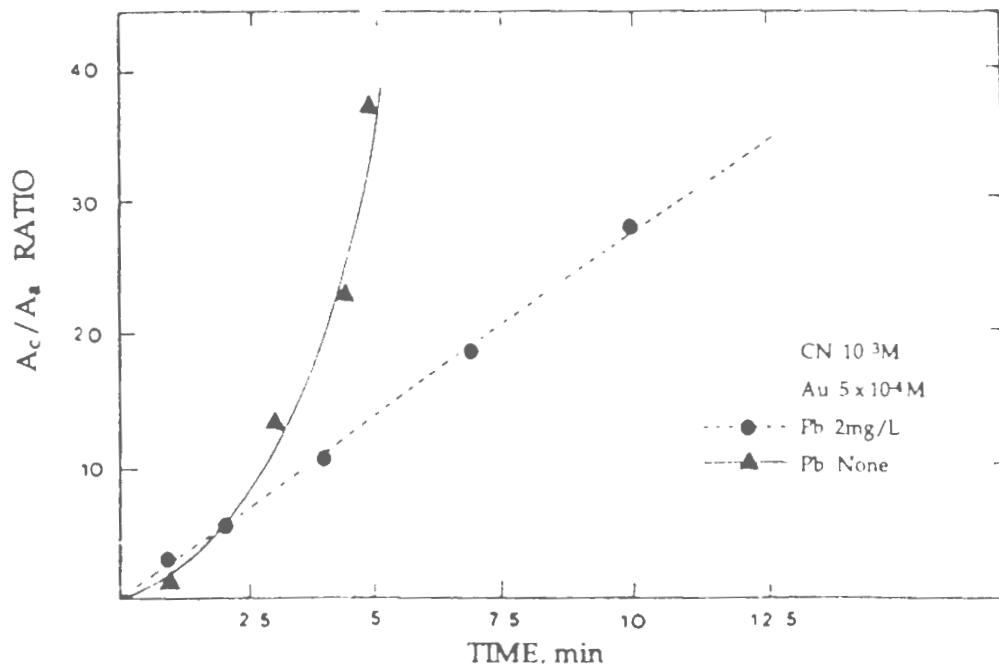

Figure 4.17. Plots of the calculated ratio A_c/A_a in the $Au(CN)_2^-/Zn$ metal displacement reaction showing the effect of lead addition. A_c and A_a are cathodic area and anodic area, respectively(11).

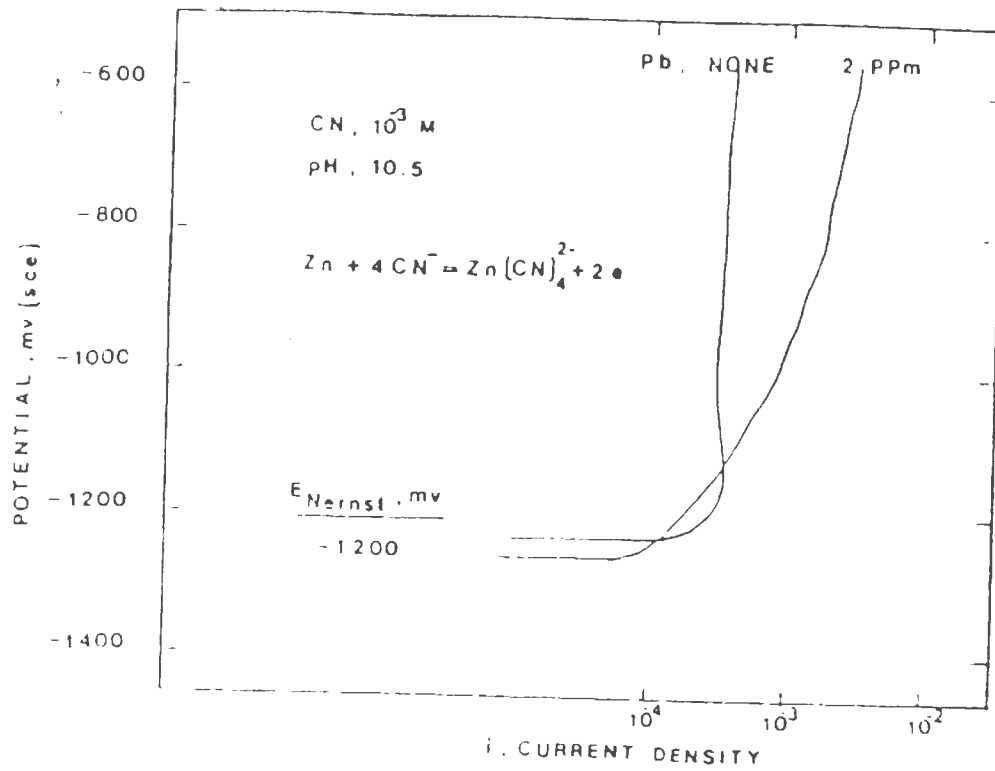
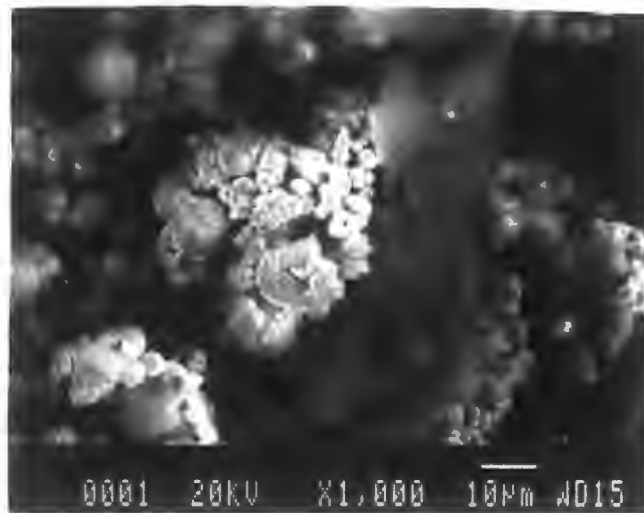
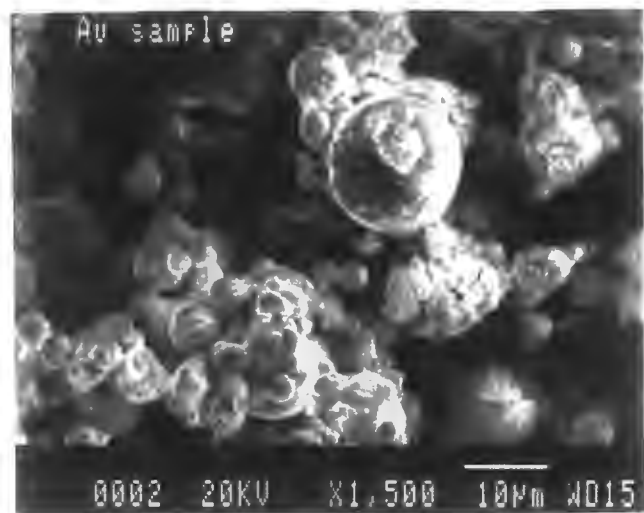

Figure 4.18. Zinc anodic polarization curves (3).



(a)



(b)

Figure 4.19. SEM photograph of gold deposit on the zinc surface; $[\text{NaCN}] = 0.1\text{g/L}$, $[\text{Au}] = 40\text{ ppm}$, $\text{pH } 10.7$, 22°C , (a) no lead, (b) 10 ppm lead nitrate.

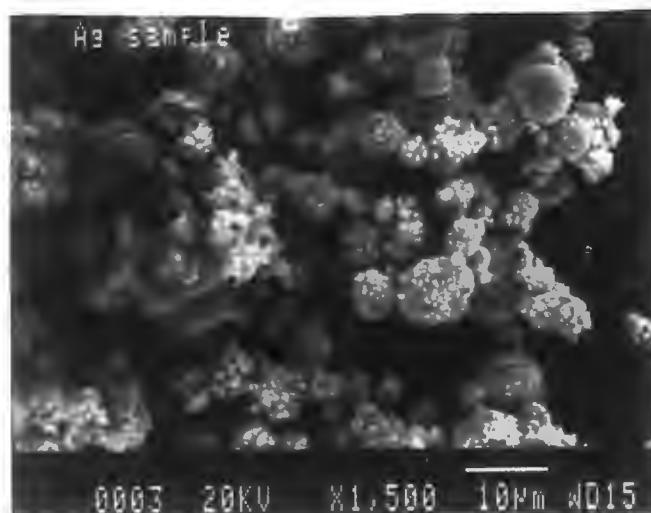

(a)

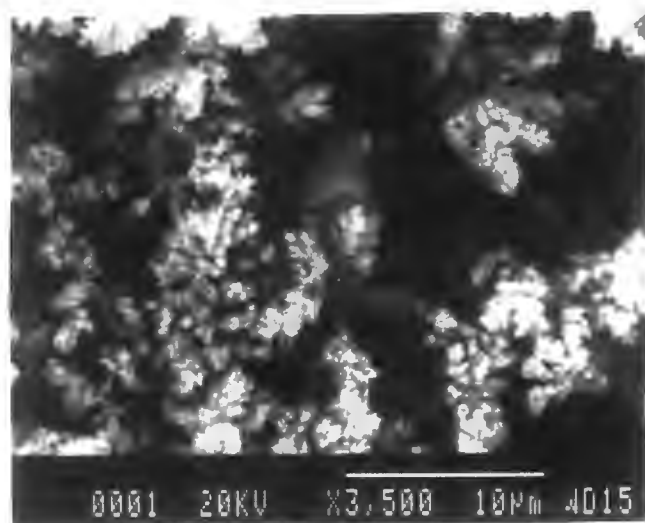

(b)

Figure 4.20. SEM photograph of silver deposit on the zinc surface; [NaCN] = 0.5g/L, [Ag] = 40 ppm, pH 10.7, 22°C, (a) no lead, (b) 10 ppm lead nitrate.

metal-bearing solutions is not similar. The enhancement in the cementation reaction could be achieved by different means. The enhancement achieved with lead nitrate additions, may be due to the change of the deposit of silver on zinc surface from a mixture of uniform layer plus dendritics to completely dendritic(Figure 4.20). Under that condition the reagents could reach the zinc surface more easily, and products could also be removed more readily.

The mechanism involved with lead addition to silver solutions cannot explain the experimental results with gold cementation. That is, only one type of deposit, a uniform layer, was found after gold cementation with and without lead nitrate addition. Similar results were also reported by Oo et al.(27). Formation of a lead - zinc couple, which can accelerate the gold cyanide reduction at cathodically charged areas of metallic lead, may be occurring, and, also, this phenomenon may prevent the zinc surface from being coated by gold.

At a lower cyanide concentrations, zinc hydroxide is present on the zinc surface. When 10 ppm lead nitrate is added to the solution, the zinc hydroxide disappears, Therefore, more metallic zinc is available for reaction with the precious metal. At low cyanide concentration, the effect of lead appears to be one of reducing the extent of formation of zinc hydroxide.

Since lead salt can enhance the efficiency of gold precipitation and, itself, be reduced by metallic zinc, more zinc should be dissolved in solution in its presence. However, the presence of lead salt will suppress the reduction of hydrogen which will reduce the consumption of zinc. The experimental

results showing the effects of lead nitrate addition on zinc solubility with different concentrations of cyanide and precious metal ion are given in Figure 4.21 (a) and (b), Figure 4.22 (a) and (b), Figure 4.23 (a) and (b), and Figure 4.24 (a) and (b). As can be noted, under these conditions, zinc solubility increases in the presence of lead nitrate except with very low cyanide concentration. See Figure 4.25. The formation of zinc hydroxide is apparently overwhelming in low cyanide solution; its coverage of zinc particles retards gold precipitation. At high cyanide concentration in silver systems, the effect of lead is one of providing conditions favorable to the formation of dendrites (Figure 4.20).

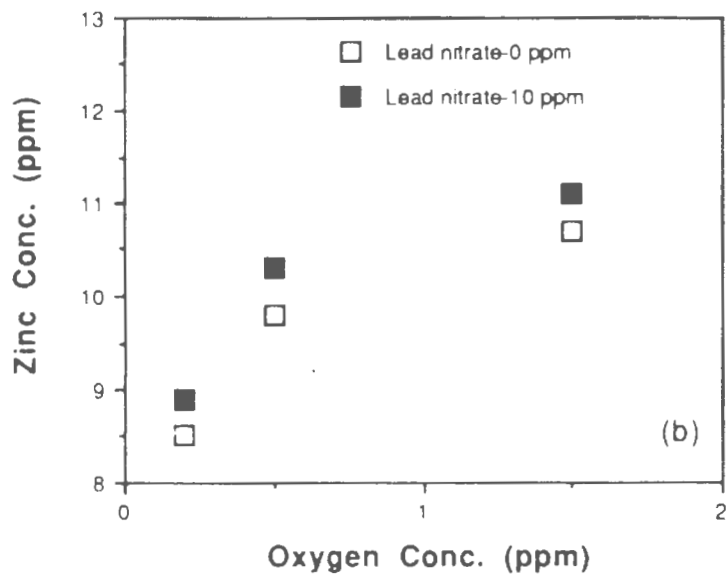
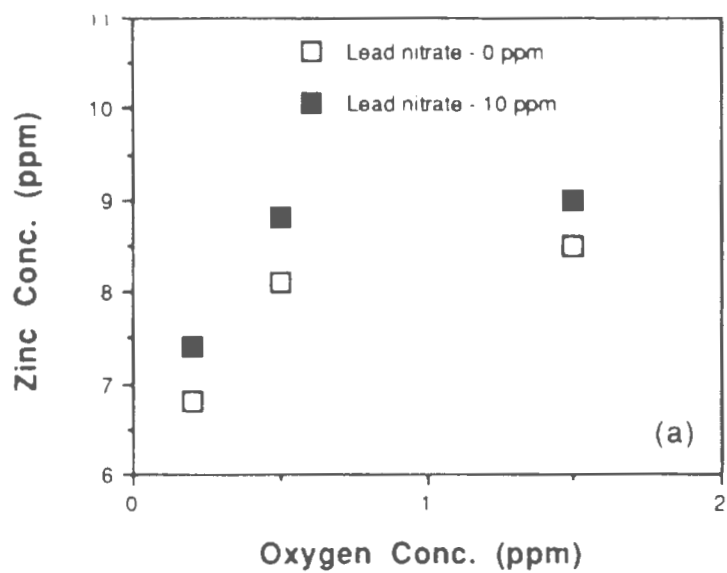

Figure 4.21. Effect of lead addition on zinc solubility in gold cyanide systems with different cyanide concentrations; $[Au] = 2$ ppm, pH 10.7, 22°C, (a) $[NaCN] = 0.1$ g/L, (b) $[NaCN] = 0.5$ g/L.

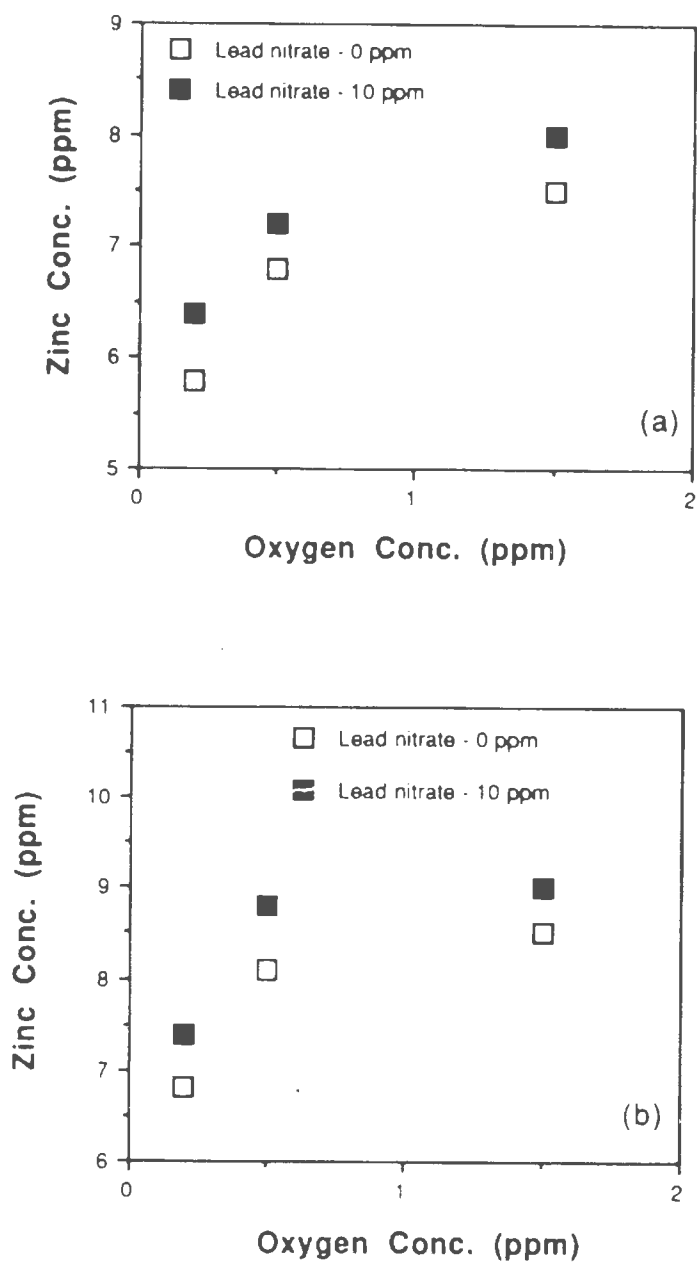

Figure 4.22. Effect of lead addition on zinc solubility in gold cyanide systems with different metal ion concentrations; [NaCN] = 0.1 g/L, pH 10.7, 22°C, (a) [Au] = 0.1 ppm, (b) [Au] = 2 ppm.

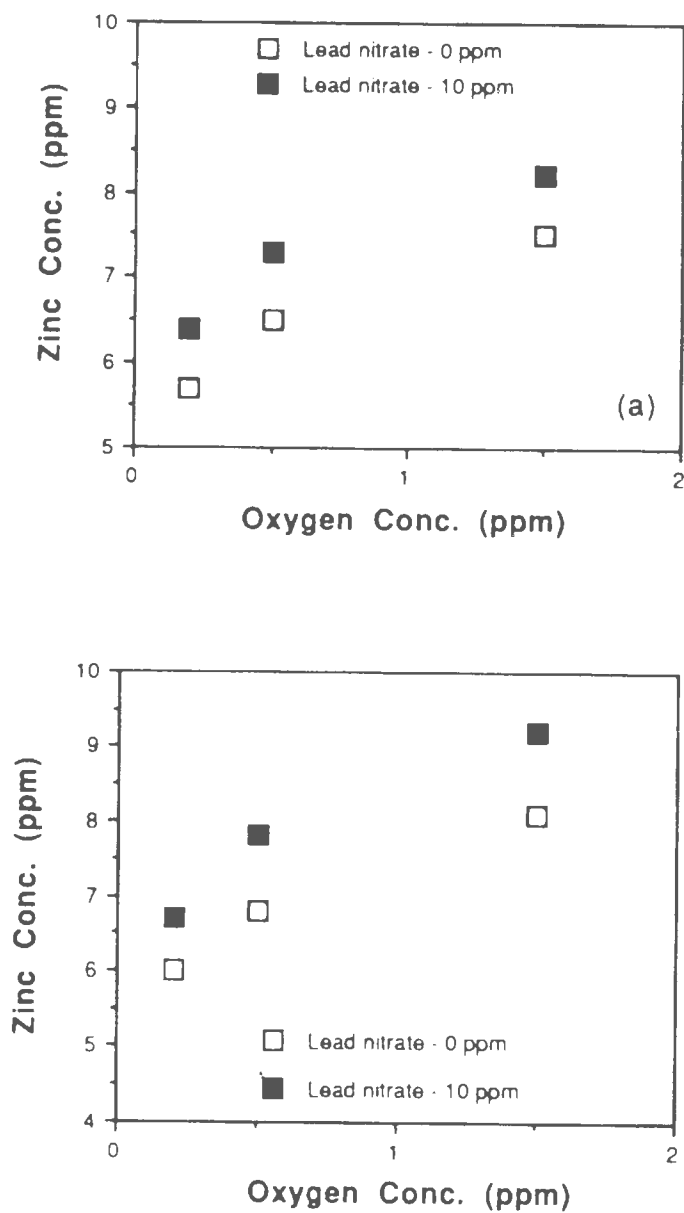

Figure 4.23. Effect of lead addition on zinc solubility in silver cyanide systems with different cyanide concentrations; [Ag] = 5 ppm, pH 10.7, 22°C, (a) [NaCN] = 0.1 g/L, (b) [NaCN] = 0.5 g/L.

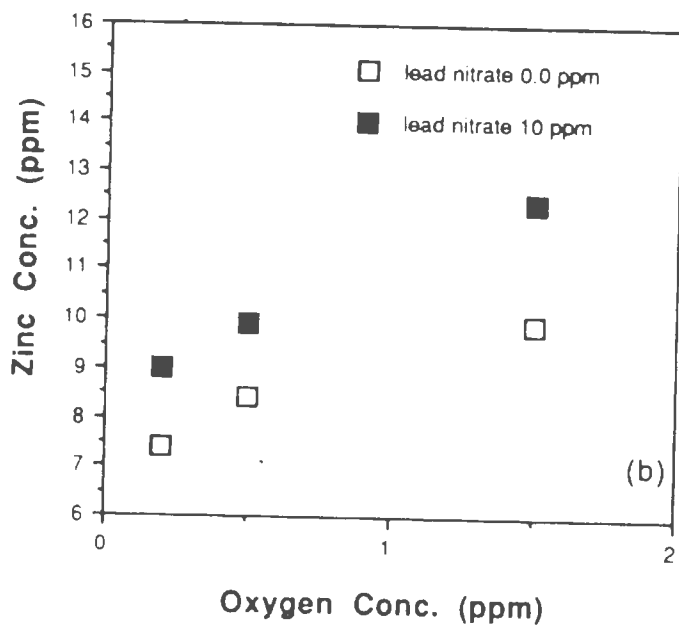
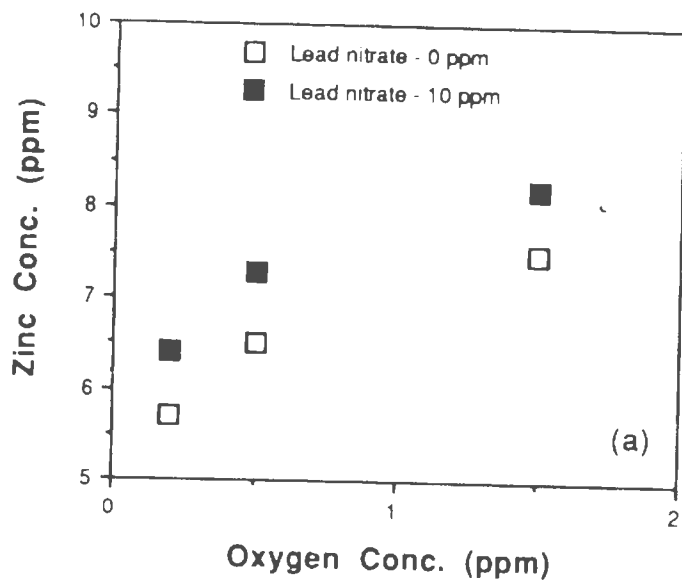

Figure 4.24. Effect of lead addition on zinc solubility in silver cyanide systems with different metal ion concentrations; $[NaCN] = 0.5$ g/L, pH 10.7, 22°C, (a) $[Ag] = 5$ ppm, (b) $[Ag] = 40$ ppm.

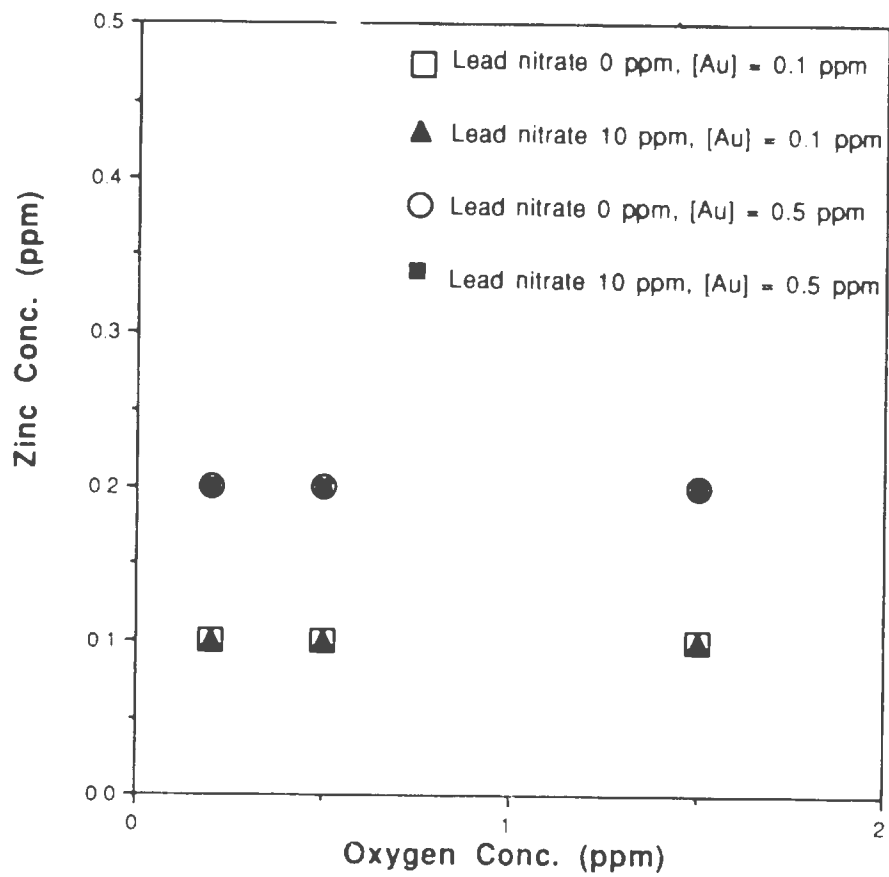

Figure 4.25. Effect of lead addition on zinc solubility; $[\text{NaCN}] = 1.5 \times 10^{-4}\text{M}$, pH 10.7, 22°C.

5. CONCLUSIONS

The following conclusions can be drawn from the results of this investigation:

1. The solubility of zinc increases with an increase in free cyanide concentration in solution. At very low cyanide concentration, the solubility of zinc is low, and the addition of lead does not show any effect.
2. The solubility of zinc increases with an increase in dissolved oxygen concentration in solution. Oxygen is a very important consumer of zinc, especially when the precious metal ion concentration is very low.
3. The solubility of zinc is sensitive to the precious metal ion concentration. Increasing metal ion concentration increases the solubility of zinc.
4. The sensitivity of precious metal ion concentration in zinc solubility changes with different chemical conditions because solubilization of zinc is achieved by two means. Accelerating the reduction of oxygen and water and accelerating the reduction of the precious metal ion can increase the solubility of zinc.
5. The solubility of zinc is increased significantly when small amounts of precious metal are present in solutions containing low concentrations of NaCN and oxygen.
6. When the deposit of precious metal covers the entire zinc surface, the reduction of oxygen and water is suppressed, and the solubility of zinc is reduced.
7. There is no single mechanism for lead salt enhancement of cementation in alkaline cyanide solutions. Lead salts can enhance the cementation reaction

by preventing the formation of zinc hydroxide; by forming a cathodic area on the zinc surface and, thereby, accelerating the reduction of precious metal ion; or by changing the morphology of the precious metal deposit on zinc.

8. In the presence of precious metal ion, the increase in zinc solubility obtained with the same level of addition of lead nitrate is essentially independent of cyanide concentration.

6. REFERENCES

1. Yannopoulos, J. C., The Extractive Metallurgy of Gold. New York NY, 1991.
2. Leblanc, R., "Precipitation of Gold from Cyanide Solution by Zinc Dust", Canadian Mining Journal, 1942.
3. Parga, J. R., "Analysis of the Zinc Cementation Reaction for Recovery of Precious Metals form Cyanide Solutions", Ph. D. Dissertation, Dept. of Metallurgy and Metallurgical Engineering, University of Utah, Salt Lake City, April, 1987.
4. Miller, J. D., "Solution Concentration and Purification", Metallurgical Treatises, Eds. John, K. T. and Elliot, J. F. (AIME), 1981, pp. 95-116.
5. Stricklan, P. H. and Lawson, F., "The Cementation of Metals from Dilute Aqueous Solution", Proc. Aust. Inst. Min. Metall., 1971, March, pp. 71-79.
6. Nicol, M. J., Schalch, E., and Balestra, P., "A Modern Study of the Kinetics and Mechanism of the Cementation of Gold", J.S. Afr. Inst. Min. Metall., 1979, Vol. 79, pp. 191-198.
7. Barin, I., Barth, H. and Yaman, A., "Electrochemical Investigations of the Kinetics of Gold Cementation by Zinc from Cyanide Solutions", Erzmetall, 1980, Vol. 33, pp. 399-403.
8. Annamalai, V. and Muir, L. E., "Influence of Deposit Morpholog the Kinetics of Copper Cementation on Pure Iron",

- Hydrometallurgy, 1979, Vol. 4, p. 57.
9. Levich, V., Physiochemical Hydrodynamics, Prentice-Hall, Englewood Cliffs, N. J., 1962.
 10. Riddiford, A., "The Rotating Disc System", Adv. Electrochem. Eng., 1966, Vol. 47, pp. 4-87
 11. Parga, J. R., Wan, R. Y. and Millar, J. D., 'Zinc Dust Cementation of Silver from Alkaline Cyanide Solutions-Analysis of Merrill-Crowe Plant Data," Min. Metall. Processing, August, 1988, pp. 170-176.
 12. Chi, G. X., "Study of Merrill-Crown Processing: Solubility of Zinc in Alkaline Cyanide Solution", M.S. Thesis, University of Nevada, February 1992.
 13. Encyclopedia of Chemical Technology, Third Edition, John Wiley and Sons, New York, 1978.
 14. Puddephatt, R. J., The Chemistry of Gold, Elsevier Scientific Publishers. Physical Science and Engineering Division, New York, 1978.
 15. Sidgwick, N. V., The Chemical Elements and Their Potentials in Aqueous Solution, Oxford, London, 1950, Vol. 1. pp. 177-79.
 16. Finkelstein, N. P., "The Chemistry of the Extraction of Gold from Its Ores", Gold Metallurgy in South Africa, Adamson, R. J., Editor, Johannesburg, Chamber of Mines of South Africa.
 17. Latimer, W. M., Oxidation Potentials, Prentice Hall, 1952, pp.

- 168-197.
18. Izatt, R. M., Johnston, H. D., Watt, G. D., and Christensen, J. J., Inorganic Chemistry, Vol. 6, 1967.
 19. Farnsworth, M. and Kline, C. H., Zinc Chemicals-Their Properties and Application, London, Zinc Development Association, New York, Zinc Institute, 1973.
 20. Sillen, L. G. and Martell, A. E., Stability Constants, Special Publication No. 17, The Chemical Society, London, 1964.
 21. Pourbaix, M., Atlas of Electrochemical Equilibrium in Aqueous Solution, Pergamon Press, New York, NY, 1966.
 22. Deitz, G. A. and Halpern, J., "Reaction of Silver with Aqueous Solutions of Cyanide and Oxygen", Trans. AIME Vol. 5, 1953, pp. 1109 -1116.
 23. Plaksin, I. N. and Badnikwa, O. K., "Oxidation-Reduction Process During Precipitation of Metals from Cyanide Solution", Ordcl. Tekh. Nauk , 1951, pp. 267-72.
 24. Halbe, D., "Recovery of Gold and Silver from Leach Solution", Heap and Dump Leaching Newsletter, May, DHL Company. Colorado, U. S. A., June, 1985, pp. 5-9.
 25. Dorr, J. V. N. and Bosqui, F. L. Cyanidation and Concentration of Gold and Silver Ores, 2nd edn., McGraw-Hill, NY, p. 511.
 26. Koryta, J., Dvorak, J. and Bohackova, V., 1973 Electrochemistry, Methuen, London, pp. 308.

27. Oo, M. T., and Tran, T., "The Effect of Lead on the Cementation of Gold by Zinc", Hydrometallurgy, Vol. 26, 1991, pp. 61-74.

Appendix: Eh-pH Diagram of Zinc-Cyanide System

Since the stability region of various species in equilibrium can be delineated clearly by Eh-pH diagrams and since Eh-pH diagrams are also helpful in understanding the reactions occurring in the cementation process, it is informative to analyze the solubility of zinc in gold and silver cyanide solution utilizing these diagrams. A part of Figure 2.5 in which chemical conditions are $[\text{CN}^-]_t = 10^{-2} \text{ M}$, $[\text{Ag}] = 2.5 \times 10^{-4} \text{ M}$ and $[\text{Zn}^{2+}] = 1.5 \times 10^{-4} \text{ M}$ is picked as an example. The equations involved are:

For equation:

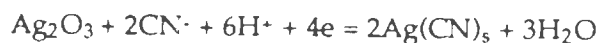

$$E^0 = 2.115\text{V}$$

and the Nernst equation is:

$$E = 2.115 - 0.0886\text{pH} - 0.0295 \text{pCN}$$

$$\text{pCN} = 9.3 + \log[4.93 \times 10^{-10} + (\text{H}^+)] - \log(\text{CN}^-)_t$$

$$\text{Thus, } E = 2.115 - 0.0886\text{pH} + 0.0295[-9.3 - \log[4.93 \times 10^{-10} + (\text{H}^+)] + \log(\text{CN}^-)_t]$$

pH	0	1	2	3	4	5	6
E(V)	1.781	1.722	1.663	1.604	1.545	1.487	1.428

For equation:

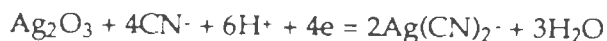

$$E^0 = 2.204\text{V}$$

and the Nernst equation is:

$$E = 2.204 - 0.0886\text{pH} - 0.0591 \text{pCN} - 0.0295 \log[\text{Ag}(\text{CN})_2^-]$$

$$E = 2.310 - 0.0886\text{pH} - 0.0591\text{pCN}$$

pH	3	4	5	6	7	8	9	10
E(V)	1.613	1.524	1.495	1.465	1.436	1.406	1.366	1.301
pH	11	12	13	14				
E(V)	1.217	1.129	1.129	1.129				

For equation:

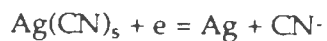

$$E^0 = -0.091\text{V}$$

and the Nernst equation is:

$$E = -0.091 + 0.0591 \text{pCN}$$

pH	0	1	2	3	4
E(V)	0.577	0.518	0.458	0.399	0.340

For equation:

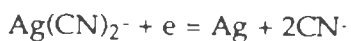

$$E^0 = -0.269\text{V}$$

and the Nernst equation is:

$$E = -0.269 + 0.0591 \log[\text{Ag}(\text{CN})_2^-] + 0.118\text{pCN}$$

$$E = -0.482 + 0.118\text{pCN}$$

pH	3	4	5	6	7	8	9	10
E(V)	0.497	0.379	0.262	0.144	0.026	-0.093	-0.190	-0.237

pH	11	12	13	14
E(V)	-0.246	-0.246	-0.246	-0.246

For equation:

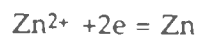

$$E^0 = -0.763\text{V}$$

and the Nernst equation is:

$$E = -0.763 + 0.0295\log(\text{Zn}^{2+})$$

$$E = -0.876\text{V}$$

For equation:

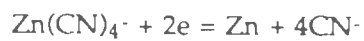

$$E^0 = -1.25\text{V}$$

and the Nernst equation is:

$$E = -1.25 + 0.0295\log[\text{Zn}(\text{CN})_4^-] + p\text{CN}$$

$$E = -1.363 + p\text{CN}$$

pH	7	8	9	10	11	12
E(V)	-0.856	-0.974	-1.071	-1.120	-1.127	-1.127

For equation:

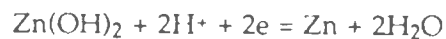

$$E^0 = -1.276\text{V}$$

and the Nernst equation is:

$$E = -0.419 - 0.0591\text{pH}$$

pH	11	12	13
----	----	----	----

E(V) -1.070 -1.128 -1.187

For equation:



$$E^0 = 0.054$$

and the Nernst equation is:

$$E = -0.059 - 0.0886\text{pH}$$

pH 12 13 14

E(V) -1.120 -1.210 -1.300

For equation:

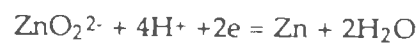

$$E^0 = 0.441\text{V}$$

and the Nernst equation is:

$$E = 0.328 - 0.118\text{pH}$$

pH 13 14

E(V) -1.209 -1.326